

Tools

13 PIECE ECONO HOLE CUTTER KIT

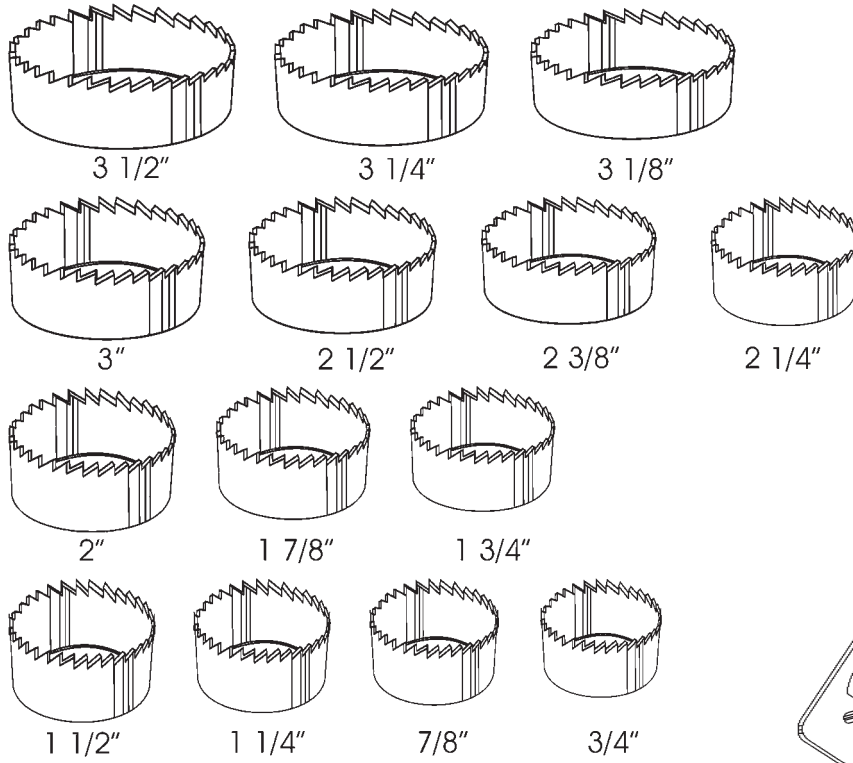

Kit Includes

- 13 Hole Cutters
3/4" - 3 1/2"
- 2 Mandrels
- 1 Adapter Plate
- 1 Allen Wrench
- 1 Carrying Case

ORDER NUMBER

47-882

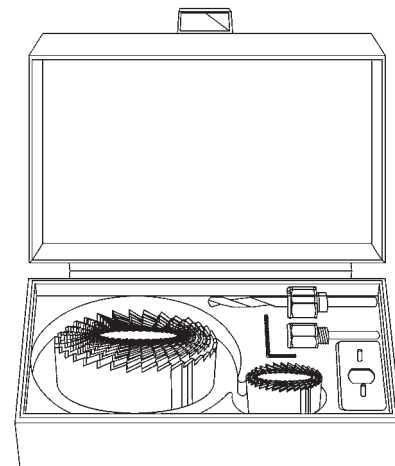
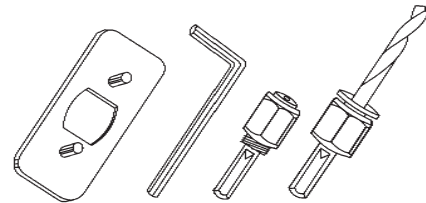

Kitchens

Doors

Kitchen
Accessories

Hinges

Drawer
Slides

Plywood
Melamine

Veneer
Edgebanding

Laminate

Solid
Surface

Closets

Furniture
Hardware

Pulls
&
Knobs

Lighting

Grommets

Locks,
Lock
Systems

Molding,
Carvings



Tools

Adhesives
Solvents
Abrasives

Chemicals
Staples
Screws

BOSCH JIG SAW BLADES

Jig Saw Blades – 5 piece card order numbers

	ORDER NUMBER	LENGTH	TEETH PER INCH	BOSCH NUMBER	RECOMMENDED APPLICATIONS			SHANK STYLE
					WOOD	METAL	OTHER	
Kitchens	47-722	3-1/8"	14	U1BR	Reverse Cut	No	Plastic Laminates	
Doors	47-728	4"	10	U101BF	Clean Cut	No	Particle & Fiber Board	
Kitchen Accessories	47-700*	4"	10	T101B	Very Clean Cut	No	No	SHANK STYLE 
Hinges	47-702	4"	6	T101D	Fast Clean Cut	No	No	
	47-716	3"	12	T119BO	Scroll Cut	No	No	
	47-704	4"	6	T144D	Fast Rough Cut	No	No	
Drawer Slides	47-706	4"	6	T244D	Curve Cutting	No	No	
	47-712	4"	10	T101BR	Down Cutting	No	Plastics & Laminates	
Plywood Melamine	47-708	4"	8	T127D	No	< 1/4" Mild Steel	No	
	47-714	3"	24	T118A	No	< 1/8" Mild Steel	Plastic & Linoleum	

< means 'Less Than'

SHANK STYLE



Fits Bosch Models:
1581, 1581VS, 1581DVS,
1582, 1582VS, 1582DVS,
JS50, 7561 111, 1577, 1578,
1580, 1580VS, 1922K



*** Bosch Number T101B**
Also available in
100 pc BULK PACK

ORDER NUMBER
47-430

SHANK STYLE



Fits Bosch Models: 3230,
3230VS, and 3238VS
plus all jig saws using
Universal Shank Blades

LAMINATE SLITTER

Portable Hand Slitter
ORDER NUMBER

47-122



**PORTABLE,
LIGHT WEIGHT
HAND SLITTER**
IS IDEAL FOR SHOP
OR USE ON THE
INSTALLATION
SITE. **REQUIRES NO
ELECTRICITY**

Replacement Cutter Wheels
ORDER NUMBER
47-182

EDGE TRIMMER

Edge Trimmer
ORDER NUMBER
33-896



Designed for quick and easy
trimming of PVC veneers, etc.

Replacement Blade**33-894**

DOUBLE EDGE VENEER TRIMMER

Double Edge Trimmer
ORDER NUMBER
47-118



Cuts both sides simultaneously.
For edges up to 22mm (7/8") width.
Top quality, long life double blades
that are easy to replace.

Replacement Blades.....**47-180**

Kitchens

Doors

Kitchen Accessories

Hinges

Drawer Slides

Plywood Melamine

Veneer Edgebanding

Laminate

Solid Surface

Closets

Furniture Hardware

Pulls & Knobs

Lighting

Grommets

Locks, Lock Systems

Molding, Carvings

Tools

Adhesives Solvents Abrasives

Chemicals Staples Screws

AMANA SAW BLADES

PRECISION TRIM



DIAMETER
10"
TEETH
60
ARBOR
5/8"

For exceptionally smooth end trimming and crosscutting in all types of natural wood and plywood

ORDER NUMBER.....47-222

PLASTIC & TRIM



DIAMETER
10"
TEETH
60
ARBOR
5/8"

General trimming and crosscutting natural woods, plywood, composition material and single or double-sided plastic laminated material

ORDER NUMBER.....47-224

LAMINATE & VENEER



DIAMETER
10"
TEETH
80
ARBOR
5/8"

Trimming and crosscutting single or double-sided veneered and plastic laminated panels

ORDER NUMBER.....47-226

Kitchens
Doors
Kitchen Accessories
Hinges
Drawer Slides
Plywood Melamine
Veneer Edgbanding



THE BLADE THAT DOES IT ALL!
EXTRA HEAVY PLATE

Tool No.	Dia.	Teeth	Bore	Grind	Hook Angle
PR1040	10"	40	5/8	ATB	18°

Application:
Ripping and crosscutting in all woods and veneered plywood.



TRIM BLADES
LEAVES A SUPER-SMOOTH FINISH

Tool No.	Dia.	Teeth	Bore	Grind	Hook Angle
610800	10"	80	5/8	ATB	10°

Application:
Ripping and crosscutting in all woods and veneered plywood.



DOUBLE-SIDED MELAMINE BLADES
CHIP-FREE CUTS ON BOTH SIDES

Tool No.	Dia.	Teeth	Bore	Grind	Hook Angle
MD10800	10"	80	5/8	H-ATB	-6°
MD12960	12"	96	1	H-ATB	-6°

Application:
Ripping and crosscutting in double-side melamine.



SOLID SURFACE BLADES
FOR FRAGILE SURFACE LAYERS, LIKE VENEERS & LAMINATES

Tool No.	Dia.	Teeth	Bore	Grind	Hook Angle
610721	10"	72	5/8	MTC	0°
612841	12"	84	1	MTC	0°

Application:
Ripping and crosscutting in solid surface and laminates.



COMBINATION BLADE
DEEP CUTS WITH IMPROVED CHIP EJECTION

Tool No.	Dia.	Teeth	Bore	Grind	Hook Angle
610504	10"	50	5/8	4&1 ATB	15°

Application:
Ripping and crosscutting in all woods and veneered plywood.



NON-FERROUS METAL BLADES
THIN-WALLED

Tool No.	Dia.	Teeth	Bore	Grind	Hook Angle
510801	10"	80	5/8	TCG	6°
512961	12"	96	1	TCG	6°

Application:
Cutting thin-walled aluminum and non-ferrous extrusions and frames.



CUT-OFF & CROSSCUT BLADES
GOOD CHOICE FOR HEAVY PRODUCTION IN CABINET MAKING SHOPS

Tool No.	Dia.	Teeth	Bore	Grind	Hook Angle
610600	10"	60	5/8	ATB	10°
612720	12"	72	1	ATB	10°

Application:
Cut-off and crosscut in woods, plywood and chipboard.



E-Z DIAL™ ADJUSTABLE SCORING SET & SLIDING TABLE SAW BLADES
FITS ALTENDORF, SCM, CASOLIN ASTRA TOP, CASADEI SHARK & LAZZARI

Tool No.	Dia.	Teeth	Bore
EZ120-24-22	120mm	12x2	22mm, 3/4" & 15mm

Chamfered dial for SCM machine.
BEZ-015 from 22 to 15mm.

Tool No.	Dia.	Teeth	Bore	Grind	Hook Angle
DT12721	12"	72	1	TCG	10°
DT12721-30	12"	72	30mm	TCG	10°
DT14841	14"	84	1	TCG	10°
DT14841-30	14"	84	30mm	TCG	10°



Laminate
Solid Surface
Closets
Furniture Hardware
Pulls & Knobs
Lighting
Grommets
Locks, Lock Systems
Molding, Carvings

Tools
Adhesives Solvents Abrasives
Chemicals Staples Screws



Amana Tool[®]
REDEFINING WOODWORKING™



Kitchens

Doors

GENERAL PURPOSE CUT-OFF BLADES

SMOOTH, CLEAN CHIP-FREE CUTS ON BOTH SIDES OF MATERIAL

Tool No.	Dia.	Teeth	Bore	Grind	Hook Angle
610601	10"	60	5/8	TCG	10°
612721	12"	72	1	TCG	10°

Application:

Cut-off and crosscut in woods, plywood and chipboard.



Kitchen Accessories

Hinges

Drawer Slides

'EURO-RIP' RIPPING BLADE

THIS EXCEPTIONAL BLADE CUTS FAST & SMOOTH

Special cooling slots in body prevent heat build-up.

Tool No.	Dia.	Teeth	Bore	Grind	Hook Angle
RB1020	10"	20	5/8	FT	20°

Application:

Ripping in soft/hardwood.



Plywood Melamine

Veneer Edgebanding

Laminate

FINE CUT-OFF & CROSSCUT BLADE

FOR FRAGILE SURFACE LAYERS, LIKE VENEERS & LAMINATES

Tool No.	Dia.	Teeth	Bore	Grind	Hook Angle
610801	10"	80	5/8	TCG	10°

Application:

Ripping and crosscutting in all veneers, laminates and chipboard.



Solid Surface

Closets

Furniture Hardware

Pulls & Knobs

BRAD POINT BORING BITS

57mm, 70mm & 77mm LONG

Tool No. Right Hand	Tool No. Left Hand	Drilling Dia.	Drilling Length	Shank	Length
201003*	301003*	3mm	18mm	10mm	57mm
201004	301004	4mm	27mm	10mm	57mm
201045	301045	4.5mm	27mm	10mm	57mm
201005	301005	5mm	27mm	10mm	57mm
201006	301006	6mm	27mm	10mm	57mm
201065	301065	6.5mm	27mm	10mm	57mm
201070	301070	7mm	27mm	10mm	57mm
201008	301008	8mm	27mm	10mm	57mm
201010	301010	10mm	27mm	10mm	57mm
201105	301105	10.5mm	27mm	10mm	57mm
201015	301015	15mm	27mm	10mm	57mm
201017	301017	17mm	27mm	10mm	57mm
201020	301020	20mm	27mm	10mm	57mm
201007	301007	1/4	27mm	10mm	57mm
201013	301013	1/2	27mm	10mm	57mm



204003*	304003*	3mm	18mm	10mm	70mm
204004	304004	4mm	35mm	10mm	70mm
204045	304045	4.5mm	35mm	10mm	70mm
204005	304005	5mm	35mm	10mm	70mm
204006	304006	6mm	35mm	10mm	70mm
204070	304070	7mm	35mm	10mm	70mm
204008	304008	8mm	35mm	10mm	70mm
204010	304010	10mm	35mm	10mm	70mm
204007	304007	1/4	35mm	10mm	70mm
204013	304013	1/2	35mm	10mm	70mm
202004	302004	4mm	44mm	10mm	77mm
202005	302005	5mm	44mm	10mm	77mm
202070	302070	7mm	44mm	10mm	77mm
202008	302008	8mm	44mm	10mm	77mm
202010	302100	10mm	44mm	10mm	77mm



* With solid carbide cutting edge

Do not use Brad Point bits in portable drills or routers.

THE PRESTIGE LINE

SUPER-FINE DADO SETS

SIX 4-WING CHIPPERS

Flat Bottom, Chip-Free Cuts!

Tool No.	Dia.	Teeth	Bore	Grind	Hook Angle
658060	8"	24	5/8	ATB	-10°
658060-1	8"	24	1	ATB	-10°

1/4" to 29/32" - adjustments can be made 1/32" increments.

Application:

Perfect crosscutting and ripping wood, melamine/laminates, veneered plywood. Set accommodates today's undersized plywoods.



DADO SET

FOUR 2-WING CHIPPERS

Cut clean dados

Tool No.	Dia.	Teeth	Bore	Grind	Hook Angle
658030	8"	24	5/8	ATB/FT	-5°
658030-1	8"	24	1	ATB/FT	-5°
658030-AK	8"	24	5/8	ATB/FT	+15°

1/8" to 13/16" groove.

Application:

Perfect crosscutting and ripping wood, melamine/laminates, veneered plywood.



THROUGH-HOLE 'V' POINT BORING BITS

57mm, 70mm & 77mm LONG

Tool No. Right Hand	Tool No. Left Hand	Drilling Dia.	Drilling Length	Shank	Length
313004	413004	4mm	25mm	10mm	57mm
313005	413005	5mm	25mm	10mm	57mm
313006	413006	6mm	25mm	10mm	57mm
313070	413070	7mm	25mm	10mm	57mm
313008	413008	8mm	25mm	10mm	57mm
313010	413010	10mm	25mm	10mm	57mm
313007	413007	1/4	25mm	10mm	57mm
313013	413013	1/2	25mm	10mm	57mm
314004	414004	4mm	40mm	10mm	70mm
314005	414005	5mm	40mm	10mm	70mm
314070	414070	7mm	40mm	10mm	70mm
314008	414008	8mm	40mm	10mm	70mm
314010	414010	10mm	40mm	10mm	70mm
314007	414007	1/4	40mm	10mm	70mm
314013	414013	1/2	40mm	10mm	70mm



Right Hand Left Hand



315005	415005	5mm	45mm	10mm	77mm
315008	415008	8mm	45mm	10mm	77mm

Do not use Through-Hole bits in portable drills or routers.



Amana Tool[®]
REDEFINING WOODWORKING™



Kitchens

Doors

Kitchen Accessories

Hinges

Drawer Slides

Plywood Melamine

Veneer Edgebanding

Laminate

Solid Surface

Closets

Furniture Hardware

Pulls & Knobs

Lighting

Grommets

Locks, Lock Systems

Molding, Carvings

Tools

Adhesives Solvents Abrasives

Chemicals Staples Screws

2 FLUTE LAMINATE FLUSH TRIMMER BITS
Carbide Tipped, Ball Bearing Pilot

For fast, smooth accurate trim cuts, shielded compact ball bearing pilot.

A



2 FLUTE ECONOMY, LAMINATE FLUSH TRIMMER ASSEMBLIES
Carbide Tipped, Ball Bearing Pilot

For fast, accurate trim cuts, economy replaceable cutter and bearing. Arbor size 1/4"

B



OVERHANG TRIM BIT
Carbide Tipped, Ball Bearing Pilot
Overhangs 1/8"

E



HINGE MORTISING BIT
High Speed Steel

Fast cutting bit for making mortises when work is started at the edge. Smooth finish left makes this bit ideal for surfacing operations. Also used where good chip clearance is important in application such as gummy wood.

C



3 FLUTE LAMINATE FLUSH TRIMMER BIT
Carbide Tipped, Ball Bearing Pilot
Gives chatter free production trimming with extra smooth flush trim cut. Compact ball bearing assembly is equipped with glue shield.

D



FLUSH TRIMMER BIT
Solid Carbide
Makes flush trim edge cut, self-pilot.

F



BEVEL TRIMMER BIT
Solid Carbide
Makes 7° bevel on trim edge cut, self-pilot.

G



BIT	ORDER NUMBER	AMANA NUMBER	CUT/BEARING DIAMETER	FLUTE/CUT LENGTH	SHANK DIAMETER	SHANK LENGTH	OVERALL LENGTH	TYPE CUT
A	47-566	47100	3/8"	1	1/4"	-	2-5/8"	-
A	47-564	47104	1/2"	1	1/4"	-	2-5/8"	-
A	47-624	47108	1/2"	1	1/2"	-	3-1/4"	-
B	47-618	47180	5/8"	5/8"	1/4"	-	2"	Flush
B	47-620	47184	3/4"	3/4"	1/4"	-	2"	Bevel
C	47-540	45500	1/2"	3/4"	1/4"	-	2"	-
D	47-512	47114	1/2"	1	1/4"	-	2-5/8"	-
E	47-514	47190	3/8"	1/2"	1/4"	-	2"	-
F	47-580	51200	-	1/4"	1/4"	-	1-1/2"	Flush
G	47-582	51202	-	1/4"	1/4"	-	1-1/2"	7° Bevel
H	47-520	45208	1/4"	3/4"	1/4"	1-1/4"	2"	-
H	47-526	45216	3/8"	3/4"	1/4"	1"	2"	-
H	47-530	45224	1/2"	3/4"	1/4"	1"	2"	-
H	47-546	45422	1/2"	1-1/2"	1/2"	1-5/8"	3-1/8"	-

H



2 FLUTE PLUNGE CUTTING
Strong webbing and heavy cutter backing give superior bit life. Specially designed tip for fast plunge cutting.

HINGE BORING BITS
57mm 2-WINGS SPURS

Tool No. Right Hand	Tool No. Left Hand	Drilling Dia.	Shank	Length
203201	203205	20mm	10mm	57mm
203221	203225	22mm	10mm	57mm
203251	413006	25mm	10mm	57mm
203261	413070	26mm	10mm	57mm
203301	413008	30mm	10mm	57mm
203351	413010	35mm	10mm	57mm
203401	413007	40mm	10mm	57mm

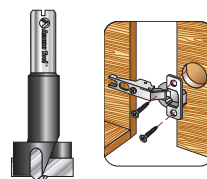

Do not use Hinge Boring bits in portable drills or routers.
Boring machines (10mm shank) & drill presses (3/8 shank).



Kitchens

Doors

Kitchen Accessories

Hinges

Drawer Slides

Plywood Melamine

Veneer Edgebanding

Laminate

Solid Surface

Closets

Furniture Hardware

Pulls & Knobs

Lighting

Grommets

Locks, Lock Systems

Molding, Carvings

Tools

Adhesives Solvents Abrasives

Chemicals Staples Screws

FLUSH TRIM PLUNGE BITS

WITH UPPER BALL BEARING • 2 FLUTE

Tool No.	Cutting Dia.	Cutting Length	Shank Dia.	Overall Length	Replacement Bearing	Collar
45460	1/2	1	1/4	2-1/2	47701	47724
45462	5/8	1	1/4	2-3/4	47712	47724
45464	3/4	1	1/4	2-1/2	47714	47724
45466	1	1	3/8	2-7/8	47722	47730
45468	1-1/8	1-1/2	1/2	3-1/2	47738	47740
45460-S	1/2	1/4	1/4	1-5/8	47701	47724



FLUSH TRIM BITS

WITH BALL BEARING GUIDE • 2 & 3 FLUTE

Tool No.	Cutting Dia.	Cutting Length	Shank Dia.	Overall Length	Flutes
*47090	1/4	1/2	1/4	2-1/4	2
*47092	1/4	1	1/4	2-1/2	2
47100	3/8	1	1/4	2-5/8	2
47102	3/8	1/2	1/4	2-1/8	2
47104	1/2	1	1/4	2-5/8	2
47106	1/2	1/2	1/4	2-1/4	2
47108	1/2	1	1/2	3-1/4	2
47114	1/2	1	1/4	2-5/8	3
47118	1/2	1	1/2	3	3



*1/4" diameter for closer inside corner cutting.
Replacement Bearing #47706

EXTRA LONG FLUSH TRIM BITS

WITH BALL BEARING GUIDE • 2 FLUTE

Tool No.	Cutting Dia.	Cutting Length	Shank Dia.	Overall Length
47124	1/2	1-1/2	1/2	3-7/8
47126	1/2	2	1/2	4-1/4



NO-FILE™ BITS

WITH BALL BEARING GUIDE • 2 FLUTE

Tool No.	Cutting Dia.	Cutting Length	Shank Dia.	Overall Length
47150	1/2	3/8	1/4	1-7/8
47152	1/2	3/8	1/2	2-1/8
47154	1/2	3/8	1/4	1-7/8

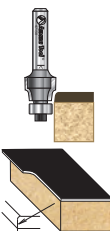

NOTE: #'s 47150-47152 are for laminates .042-.052 thick (1.5mm radius). #47154 for laminates .025-.038 thick (.4mm radius).

FLUSH TRIM 'V' GROOVE BITS

WITH BALL BEARING GUIDE • 2 FLUTE

Tool No.	Cutting Dia.	Cutting Length	Shank Dia.	Overall Length
47160	5/8	1	1/4	2-1/2
47162	5/8	1	1/2	3



Replacement Bearing #47706

'OVERHANG' TRIM BITS

WITH BALL BEARING GUIDE • 2 FLUTE

Tool No.	Cutting Dia.	Cutting Length	Shank Dia.	Overall Length	'A' Overhang Width
47190	3/8	1/2	1/4	2	1/8

'A'

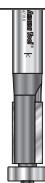

Replacement bearing #47718.

BEADING BITS

WITH BALL BEARING GUIDE • 2 FLUTE

Tool No.	Radius	Cutting Dia.	Cutting Length	Shank Dia.	Overall Length
49600	3/16	7/8	1/2	1/4	2
49604	1/4	1	1/2	1/4	2
49612	3/8	1-1/4	5/8	1/4	2-3/16
49616	1/2	1-1/2	3/4	1/4	2-1/4

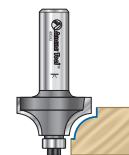

Replacement bearing #47702.

CORNER ROUNDING BITS

WITH BALL BEARING GUIDE • 2 FLUTE

Tool No.	Radius	Cutting Dia.	Cutting Length	Shank Dia.	Overall Length
49496	1/8	3/4	3/8	1/4	2
49500	3/16	7/8	1/2	1/4	2
49504	1/4	1	1/2	1/4	2
49506	1/4	1	1/2	1/2	2-7/16
49512	3/8	1-1/4	5/8	1/4	2-3/16
49514	3/8	1-1/4	5/8	1/2	2-9/16
49516	1/2	1-1/2	3/4	1/4	2-1/4
49518	1/2	1-1/2	3/4	1/2	2-5/8
49520	3/4	2	1	1/2	2-7/8
49522	1	2-1/2	1-1/4	1/2	3-3/16
49524	1-1/4	3	1-1/2	1/2	3-1/4
49526	1-1/2	3-1/2	1-3/4	1/2	3-5/8

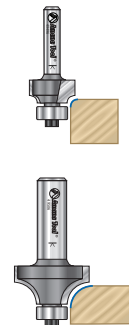

Replacement bearing #47706.

TAMBOUR ROUTER BIT SET

2 FLUTE

Designed by Lonnie Bird
U.S. Patent No. 7,810,532



Tool No.
54314 Complete 3 Piece Set

The minimum radius for the tambour door is 3-1/2"

SOLID CARBIDE PANEL PILOT BITS

SINGLE FLUTE

Tool No.	Type of Cut	Cutting Dia.	Cutting Length	Shank Dia.	Overall Length
51200	Flush	1/4	1/4	1/4	1-1/2
51202	7°	1/4	1/4	1/4	1-1/2



PANEL PILOT BITS

SINGLE FLUTE

Tool No.	Cutting Dia.	Cutting Length	Shank Dia.	Overall Length
45506	1/4	3/4	1/4	2-1/2
45508	3/8	1	3/8	3
45510	1/2	1-3/16	1/2	3-1/2

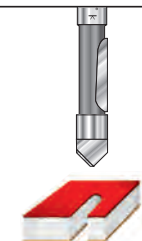



Kitchens

Doors

Kitchen Accessories

Hinges

Drawer Slides

Plywood Melamine

Veneer Edgebanding

Laminate

Solid Surface

Closets

Furniture Hardware

Pulls & Knobs

Lighting

Grommets

Locks, Lock Systems

Molding, Carvings

Tools

Adhesives Solvents Abrasives

Chemicals Staples Screws

BEVEL TRIM BITS

WITH BALL BEARING GUIDE • 2 FLUTE

Tool No.	Bevel Degree	Cutting Length	Shank Dia.	Overall Length
47200	15°	9/32	1/4	1-7/8
47202	25°	9/32	1/4	1-7/8
47204	45°	1/4	1/4	1-7/8

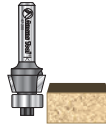

MORTISING BITS

2 FLUTE

Tool No.	Cutting Dia.	Cutting Length	Shank Dia.	Overall Length
45500	1/2	3/4	1/4	2
45502	5/8	3/4	1/4	2
45504	3/4	3/4	1/4	2
45505	1-1/4	3/4	1/2	2-1/8

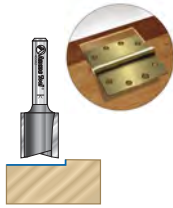

STRAIGHT PLUNGE BITS

2 FLUTE

Tool No.	Cutting Dia.	Cutting Length	Shank Dia.	Overall Length
45190	1/16	1/4	1/4	1-5/8
45192	3/32	1/4	1/4	1-3/4
45200	1/8	7/16	1/4	2
45201	5/32	7/16	1/4	2
45202	3/16	7/16	1/4	2
45210	1/4	1	1/4	2-1/4
*45110	1/4	1	1/4	3-1/4
45211	1/4	1	1/4	2-7/8
45212	9/32	1	1/4	2-1/4
45214	5/16	1	1/4	2-1/4
45218	3/8	1	1/4	2-1/4
45222	7/16	1	1/4	2-1/8
45226	1/2	1	1/4	2-1/8
45228	5/8	3/4	1/4	2
45230	3/4	3/4	1/4	2
45232	13/16	3/4	1/4	2
45234	7/8	3/4	1/4	2
45236	1	3/4	1/4	2
45408	1/4	3/4	1/2	2-1/2
45412	5/16	1	1/2	2-3/4
45414	3/8	1	1/2	2-3/4
45416	7/16	1-1/4	1/2	3
45418	1/2	1	1/2	2-5/8
45420	1/2	1-1/4	1/2	2-7/8
45422	1/2	1-1/2	1/2	3-1/8
45426	1/2	2	1/2	4-1/4
45427	1/2	2-1/2	1/2	4-1/2
45428	9/16	1-1/4	1/2	2-7/8
45432	5/8	1-1/4	1/2	2-7/8
45440	3/4	1-1/4	1/2	2-7/8
45445	23/32	1-1/4	1/2	2-7/8
45446	7/8	1-1/4	1/2	2-7/8
45448	1	1-1/4	1/2	2-7/8

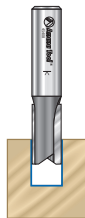
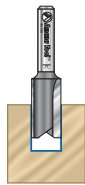

*Specifically designed for air powered routers as in the boat manufacturing industry.

2-PIECE STILE & RAIL SETS

WITH BALL BEARING GUIDE • 2 WING

For 3/4" Material

Tool No.	Type	Cutting Dia.	Cutting Length	Shank Dia.	Overall Length
55441	Bead	1-5/8	11/16	1/2	3-1/8
55421	Concave	1-5/8	11/16	1/2	3-1/8
55431	Ogee	1-5/8	1/16	1/2	3-1/8

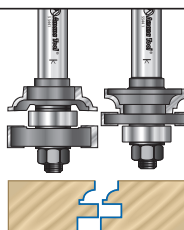

FLAT PANEL CABINET DOOR SETS

WITH BALL BEARING GUIDE • 2 WING
CUTS FRAME STOCK FROM 5/8" - 1-1/4"

SAY GOODBYE TO LOOSE FLAT PANELS
THE PERFECT FIX FOR UNDERSIZED PLYWOODS

Tool No.	Type	Cutting Dia.	Cutting Depth	Shank Dia.	Overall Length
55433	Concave	1-5/8	3/8	1/2	3-11/32
55436	Ogee	1-5/8	3/8	1/2	3-11/32
55437	Bead	1-5/8	3/8	1/2	3-11/32
55438	Mission	1-5/8	3/8	1/2	3-11/32
55439	Mission	1-7/8	1/2	1/2	3-11/32
55432	18° Bevel	1-7/8	1/2	1/2	3-11/32

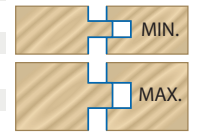

REVERSIBLE STILE & RAIL ASSEMBLIES

WITH BALL BEARING GUIDE • 2 WING • 1/2" SHANK

Tool No.	Type	Cutting Dia.	Cutting Length	'A' Reveal	Overall Length
55350	Ogee	1-5/8	7/8	1/2	3
55370	Traditional	1-5/8	7/8	1/2	3
55380	Classical	1-5/8	7/8	1/2	3

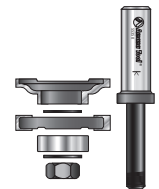

TRADITIONAL RAISED PANEL BIT

WITH BALL BEARING GUIDE • 2 FLUTE • 1/2" SHANK

Tool No.	Reveal	Angle Degree	Cutting Dia.	Cutting Length	Overall Length
△ 54117	*1-7/16	15°	3-3/8	1/2	2-3/8

*Total Reveal - Replacement bearing #47706.

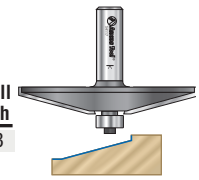

OGEE RAISED PANEL BIT

WITH BALL BEARING GUIDE • 2 FLUTE • 1/2" SHANK

Tool No.	Reveal	Each Radius	Cutting Dia.	Cutting Length	Overall Length
△ 54118	*1-1/16	3/4	2-5/8	5/8	2-1/2
△ 54121	*1-7/16	7/8	3-3/8	9/16	2-1/2

*Total Reveal - Replacement bearing #47706.

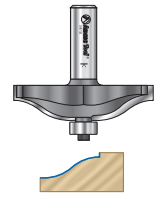

COVE RAISED PANEL BIT

WITH BALL BEARING GUIDE • 2 FLUTE • 1/2" SHANK

Tool No.	Reveal	Each Radius	Cutting Dia.	Cutting Length	Overall Length
△ 54119	*1-1/16	1-9/16	3-3/8	1/2	2-3/8

*Total Reveal - Replacement bearing #47706.

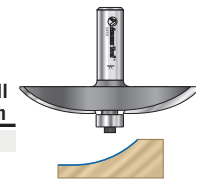

BOX JOINT ASSEMBLY

3 WING • UPPER BALL BEARING GUIDE

Tool No.	Cutting Dia.	Shank Dia.	Overall Length
53610	1-7/8	1/2	3-3/4

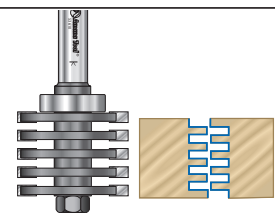



Kitchens

Doors

Kitchen Accessories

Hinges

Drawer Slides

Plywood Melamine

Veneer Edgbanding

Laminate

Solid Surface

Closets

Furniture Hardware

Pulls & Knobs

Lighting

Grommets

Locks, Lock Systems

Molding, Carvings

Tools

Adhesives Solvents Abrasives

Chemicals Staples Screws

FINGER JOINT ASSEMBLY

2 WING • UPPER BALL BEARING GUIDE

European Chip-Breaker Type

Tool No.	Cutting Dia.	Shank Dia.	Overall Length
55392	1-9/16	1/2	3-3/4

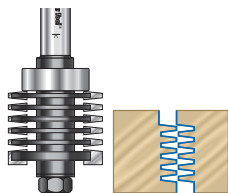

GLUE JOINT BIT

2 FLUTE

Tool No.	Cutting Dia.	Cutting Length	Shank Dia.	Overall Length
55388	1-7/8	1-3/32	1/2	2-5/8

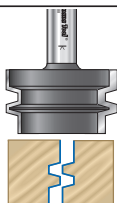

45° LOCK MITER BITS

2 FLUTE

Tool No.	Cutting Dia.	Cutting Length	Shank Dia.	Overall Length	Material Size
55390	2-11/16	1-3/16	1/2	2-5/8	1/2-7/8
55393	1/2	1/2	1/4	1-5/8	5/16-7/16

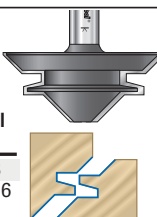

SLOTting CUTTER ASSEMBLIES

3 WING

Tool No.	Cutting Dia.	Cutting Depth	Shank Dia.	Overall Length
53400	1-7/8	1/2	1/4	1/16 2-1/8
53402	1-7/8	1/2	1/4	5/64 2-1/8
53404	1-7/8	1/2	1/4	3/32 2-1/8
53406	1-7/8	1/2	1/4	1/8 2-1/8
53407	1-7/8	1/2	1/4	5/32 2-1/8
53408	1-7/8	1/2	1/4	3/16 2-1/8
53410	1-7/8	1/2	1/4	1/4 2-1/8



WEDGE TONGUE & GROOVE SET

2 FLUTE

Tool No.	Large Dia.	Small Dia.	Cutting Length	Shank Dia.	Overall Length
55414	1-1/4	9/16	1-1/4	1/2	2-3/4

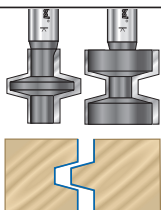

TONGUE & GROOVE ASSEMBLIES

WITH BALL BEARING GUIDE • 2-WING

Tool No.	Cutting Dia.	Material Size	Depth of Cut	Shank Dia.	Overall Length
55408†	1-5/8	3/8-1/2	3/8	1/2	3
55405†	1-5/8	1/2-3/4	3/8	1/2	3
55400	1-5/8	1/2-3/4	3/8	1/2	3
55401†	1-7/8	3/4-1-1/8	1/2	1/2	3

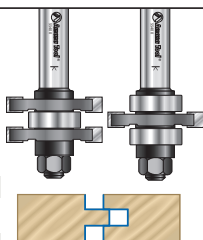

† 2-Piece Set

QUADRASET™ ADJUSTABLE SLOTTING ASSEMBLY

WITH BALL BEARING GUIDE • 2-WING

Tool No.	Cutting Dia.	Kerf	Shank Dia.	Overall Length
53600	1-7/8	1/8-23/32	1/2	3

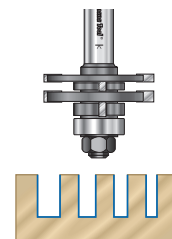

T-SLOT BITS

2 FLUTE

Tool No.	Large Dia.	Small Dia.	Kerf	Cutting Length	Shank Dia.	Overall Length
45660	1-1/8	3/8	5/16	13/16	1/2	2-1/2
45662	1-3/8	1/2	3/8	7/8	1/2	2-1/2



Note: These tools are designed for 'groove-forming' T-slot wall panels. They are not designed for plunging operations.

SPECIAL AMEROCK™ HINGE BITS

2 FLUTE

Tool No.	Large Dia.	Small Dia.	Cutting Length	Shank Dia.	Overall Length
48100	1-1/8	3/8	21/32	3/8	2
48102	1-19/32	3/8	21/32	3/8	2

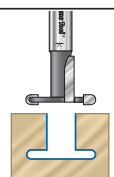

KEYHOLE BITS

SINGLE FLUTE

Tool No.	Cutting Dia.	Cutting Depth	Shank Dia.	Overall Length
45650	3/8	3/8	1/4	1-1/2
45652	1/2	3/8	1/4	1-1/2

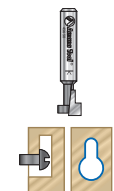

DOVETAIL BITS

2 FLUTE

Tool No.	Degree	Cutting Dia.	Cutting Length	Shank Dia.	Overall Length
45800	9°	3/8	3/8	1/4	1-5/8
45802	9°	3/8	3/8	1/2	2-1/8
45804	14°	1/2	1/2	1/4	2-3/8
45806	14°	1/2	1/2	1/2	2-3/8

Replacement bearing #47712, Snap ring #47752.

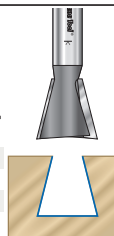

DOVETAIL, CORE BOX & 'V' GROOVE BITS

WITH UPPER BALL BEARING GUIDE • 2 FLUTE

Tool No.	Degree	Cutting Dia.	Cutting Length	Shank Dia.	Overall Length
45750	90° V-Groove	3/8	3/8	1/4	1-5/8
45850	14° Dovetail	3/8	3/8	1/2	2-1/8
45950	Core Box	1/2	1/2	1/4	2-3/8

Replacement bearing #47701, Replacement collar #47724.





Kitchens

Doors

Kitchen Accessories

Hinges

Drawer Slides

Plywood Melamine

Veneer Edgbanding

Laminate

Solid Surface

Closets

Furniture Hardware

Pulls & Knobs

Lighting

Grommets

Locks, Lock Systems

Molding, Carvings

Tools

Adhesives Solvents Abrasives

Chemicals Staples Screws

90° & 60° 'V' GROOVE BITS 2 FLUTE

Tool No.	Degree	Cutting Dia.	Cutting Length	Shank Dia.	Overall Length
45700	90°	3/8	7/16	1/4	1-5/8
45704	90°	1/2	1/2	1/4	1-5/8
45705	60°	1/2	5/8	1/4	1-3/4



NOTE: 90° 'V' Groove Bits are for decorative purposes and are not intended for 'miter-folding', etc.

SIGNMAKING/LETTERING BIT SOLID CARBIDE • 3 FLUTE

Tool No.	Degree	Cutting Dia.	Cutting Length	Shank Dia.	Overall Length
45730	60°	9/16	7/16	1/4	2-1/4



RABBETING BITS WITH BALL BEARING GUIDE • 2 FLUTE RABBET DEPTH 3/8"

Tool No.	Cutting Dia.	Cutting Length	Shank Dia.	Overall Length
49300	1-1/4	1/2	1/4	2
49302	1-1/4	1/2	1/2	2-3/8



MULTI-RABBETING BITS 2 FLUTE • INCLUDES 6 BALL BEARING GUIDES RABBET DEPTHS 1/8", 1/4", 5/16", 3/8", 7/16", 1/2"

Tool No.	Cutting Dia.	Cutting Length	Shank Dia.	Overall Length
49340	1-3/8	1/2	1/4	2
49350	1-3/8	1/2	1/2	2-3/8

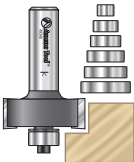

SUPERRABBET™ BITS WITH BALL BEARING GUIDES • 2 FLUTE

Tool No.	Cutting Dia.	Cutting Length	Shank Dia.	Overall Length
49360	2	7/8	1/2	3

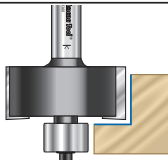

67500 - 6pc collar set for Flush, 1/16, 1/8, 1/4, 3/8, 1/2 rabbets
67600 - 5pc collar set for 3/16, 5/16, 7/16, 9/16, 11/16 rabbets
67700 - 5pc collar set for 15/64, 23/64, 15/32, 19/32, 23/32 rabbets

SPIRAL FLUTE PLUNGE SOLID CARBIDE 2 FLUTE

'Up-cut' Tool No.	'Down-cut' Tool No.	Cutting Dia.	Cutting Length	Shank Dia.	Overall Length
46100	46200	1/8	1/2	1/4	2
46101	46201	3/16	3/4	1/4	2
46102	46202	1/4	3/4	1/4	2-1/2
46316	46416	1/4	1-1/8	1/4	3
46318	46418	5/16	1-1/8	1/2	3
46103	46203	3/8	1	3/8	2-1/2
46320	46420	3/8	1-1/4	3/8	3
46104	46204	3/8	1-1/4	1/2	3
46106	46206	1/2	1-1/4	1/2	3
46107	46207	1/2	1-5/8	1/2	3-1/2
46109	46209	3/4	1-5/8	3/4	4

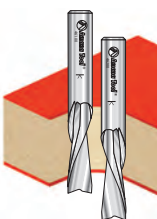

INVECTRA™ METAL LAMINATE TRIM BITS

METAL LAMINATE TRIM BITS SOLID CARBIDE • 2 FLUTE

Tool No.	Cutting Dia.	Cutting Height	Shank Dia.	Overall Length
51430	1/4	5/8	1/4	2-3/8
51432	1/2	5/8	1/2	3-1/4



Recommended by Formica® & ATI®

SOLID CARBIDE PLASTIC SPIRAL 'O' FLUTE SINGLE FLUTE Mirror Finish

Tool No.	Cutting Dia.	Cutting Height	Shank Dia.	Overall Length	Type
51404	1/4	3/4	1/4	2	Up-Cut
51504	1/4	3/4	1/4	2	Down-Cut



SOLID CARBIDE ALUMINUM SPIRAL 'O' FLUTE SINGLE FLUTE Mirror Finish

Tool No.	Cutting Dia.	Cutting Height	Shank Dia.	Overall Length	Type
51402	1/4	5/8	1/4	2	Up-Cut
51504	1/4	5/8	1/4	2	Down-Cut



COMPRESSION SPIRAL SOLID CARBIDE FOR MDF/LAMINATE 2 FLUTE & 3 FLUTE

Designed for CNC use.

Tool No.	Cutting Dia.	Cutting Height	Shank Dia.	Overall Length	Flutes
46170	1/4	7/8	1/4	2-1/2	2
46188	1/2	1-1/4	1/2	3	2
46190	1/2	1-5/8	1/2	3-1/2	2
46194	5/8	2	5/8	4	2
46198	3/4	2	3/4	4	2
46010	3/8	1-1/8	3/8	3	3
46012	1/2	1-1/4	1/2	3	3

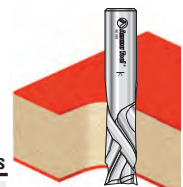

CORE BOX BITS 2 FLUTE

Tool No.	Radius	Cutting Dia.	Cutting Length	Shank Dia.	Overall Length
45904	1/8	1/4	1/4	1/4	1-5/8
45906	3/16	3/8	1/4	1/4	1-1/2
45910	1/4	1/2	3/8	1/4	1-1/2
45918	3/8	3/4	7/16	1/4	1-3/4

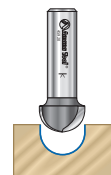



Amana Tool[®]
REDEFINING WOODWORKING™



Kitchens

Doors

Kitchen Accessories

Hinges

Drawer Slides

Plywood Melamine

Veneer Edgebanding

Laminate

Solid Surface

Closets

Furniture Hardware

Pulls & Knobs

Lighting

Grommets

Locks, Lock Systems

Molding, Carvings

Tools

Adhesives Solvents Abrasives

Chemicals Staples Screws

CHAMFER BITS

WITH BALL BEARING GUIDE • 2 FLUTE

Tool No.	Angle	Cutting Dia.	Each Height	Cutting Length	Shank Dia.	Overall Length
49400	45°	1-1/4	1/2	5/8	1/4	2
49402	45°	1-1/4	1/2	5/8	1/2	2-3/8
49404	45°	2	3/4	1-1/8	1/2	2-1/2
49406	45°	2-1/2	1	1-3/8	1/2	2-7/8
49410	22-1/2°	1-1/4	15/16	7/8	1/2	2-7/8
49414	30°	1-3/8	3/4	7/8	1/2	2-3/4



Replacement bearings: #'s 49400, 49402, 49412 & 49414 use #47704. All other tools use #47706.

FINGER GRIP/DOOR LIP BIT

2 FLUTE

Tool No.	Cutting Dia.	Each Radius	Carbide Height	Shank Dia.	Overall Length
53812	2	1/4	1-1/4	1/2	2-3/4

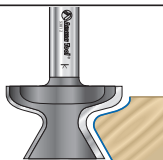

COVE BITS

WITH BALL BEARING GUIDE • 2 FLUTE

Tool No.	Radius	Cutting Dia.	Cutting Length	Shank Dia.	Overall Length
49104	1/4	7/8	9/16	1/4	2
49112	3/8	1-1/8	9/16	1/4	2
49116	1/2	1-3/8	3/4	1/4	2-1/4



BULLNOSE BITS

WITH BALL BEARING GUIDE • 2 FLUTE

Tool No.	Material Thickness	Cutting Radius	Cutting Length	Shank Dia.	Overall Length	
51572	3/4	3/8	1-5/16	1-3/8	1/2	3-1/4
51570	1/2	17/64	1	1-1/16	1/2	2-7/8

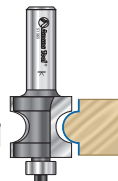

BULLNOSE BITS

2 FLUTE

Tool No.	Material Thickness	Cutting Radius	Cutting Length	Shank Dia.	Overall Length	
51558	1/2	17/64	1	1-1/32	1/2	2-1/2
51560	3/4	3/8	1-5/16	1-1/4	1/2	2-3/4
51562	1	1/2	1-9/16	1-11/16	1/2	3-1/16
51556	3/8	13/64	3/4	7/8	1/2	2-1/4

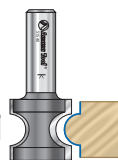

ROMAN OGEE BITS

WITH BALL BEARING GUIDE • 2 FLUTE

Tool No.	Cutting Dia.	Each Radius	Cutting Length	Shank Dia.	Overall Length
49200	1	5/32	5/8	1/4	2-1/8
49202	1	5/32	5/8	1/2	2-1/2
49204	1-3/8	1/4	7/8	1/4	2-1/4

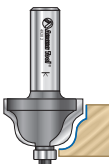

Replacement bearing #47704.

Warning: Maximum RPM \triangle_{10} = 10,000; \triangle_{12} = 12,000; \triangle_{14} = 14,000; \triangle_{16} = 16,000; \triangle_{18} = 18,000; \triangle_{20} = 20,000; \triangle_{22} = 22,000

BRAD POINT BORING BITS

57mm, 70mm & 77mm LONG

Tool No. Right Hand	Tool No. Left Hand	Drilling Dia.	Drilling Length	Shank	Length
201003*	301003*	3mm	18mm	10mm	57mm
201004	301004	4mm	27mm	10mm	57mm
201045	301045	4.5mm	27mm	10mm	57mm
201005	301005	5mm	27mm	10mm	57mm
201006	301006	6mm	27mm	10mm	57mm
201065	301065	6.5mm	27mm	10mm	57mm
201070	301070	7mm	27mm	10mm	57mm
201008	301008	8mm	27mm	10mm	57mm
201010	301010	10mm	27mm	10mm	57mm
201105	301105	10.5mm	27mm	10mm	57mm
201015	301015	15mm	27mm	10mm	57mm
201017	301017	17mm	27mm	10mm	57mm
201020	301020	20mm	27mm	10mm	57mm
201007	301007	1/4	27mm	10mm	57mm
201013	301013	1/2	27mm	10mm	57mm
204003*	304003*	3mm	18mm	10mm	70mm
204004	304004	4mm	35mm	10mm	70mm
204045	304045	4.5mm	35mm	10mm	70mm
204005	304005	5mm	35mm	10mm	70mm
204006	304006	6mm	35mm	10mm	70mm
204070	304070	7mm	35mm	10mm	70mm
204008	304008	8mm	35mm	10mm	70mm
204010	304010	10mm	35mm	10mm	70mm
204007	304007	1/4	35mm	10mm	70mm
204013	304013	1/2	35mm	10mm	70mm
202004	302004	4mm	44mm	10mm	77mm
202005	302005	5mm	44mm	10mm	77mm
202070	302070	7mm	44mm	10mm	77mm
202008	302008	8mm	44mm	10mm	77mm
202010	302100	10mm	44mm	10mm	77mm

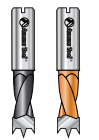

Right Hand Left Hand



* With solid carbide cutting edge
Do not use Brad Point bits in portable drills or routers.

THROUGH-HOLE 'V' POINT BORING BITS

57mm, 70mm & 77mm LONG

Tool No. Right Hand	Tool No. Left Hand	Drilling Dia.	Drilling Length	Shank	Length
313004	413004	4mm	25mm	10mm	57mm
313005	413005	5mm	25mm	10mm	57mm
313006	413006	6mm	25mm	10mm	57mm
313070	413070	7mm	25mm	10mm	57mm
313008	413008	8mm	25mm	10mm	57mm
313010	413010	10mm	25mm	10mm	57mm
313007	413007	1/4	25mm	10mm	57mm
313013	413013	1/2	25mm	10mm	57mm
314004	414004	4mm	40mm	10mm	70mm
314005	414005	5mm	40mm	10mm	70mm
314070	414070	7mm	40mm	10mm	70mm
314008	414008	8mm	40mm	10mm	70mm
314010	414010	10mm	40mm	10mm	70mm
314007	414007	1/4	40mm	10mm	70mm
314013	414013	1/2	40mm	10mm	70mm
315005	415005	5mm	45mm	10mm	77mm
315008	415008	8mm	45mm	10mm	77mm



Right Hand Left Hand



Do not use Through-Hole bits in portable drills or routers.



Kitchens

Doors

Kitchen Accessories

Hinges

Drawer Slides

Plywood Melamine

Veneer Edgebanding

Laminate

Solid Surface

Closets

Furniture Hardware

Pulls & Knobs

Lighting

Grommets

Locks, Lock Systems

Molding, Carvings

Tools

Adhesives Solvents Abrasives

Chemicals Staples Screws

CLASSICAL BITS

WITH BALL BEARING GUIDE • 2 FLUTE

Tool No.	Material Thickness	Radius	Cutting Length	Tool Dia.	Shank Dia.	Overall Length
54102	1-1/4	13/64	5/16	1/2	1/4	2
54106	1-1/2	7/32	15/64	5/8	1/4	2-1/8

Replacement bearing #47706.



WAVY EDGE BITS

WITH BALL BEARING GUIDE • 2 FLUTE

Tool No.	Cutting Dia.	Each Radius	Cutting Length	Shank Dia.	Overall Length
54180	1-1/4	5/32	11/16	1/4	2-1/4

Replacement bearing #47706.

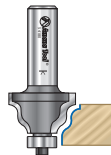

MATCHED BEAD BITS

WITH BALL BEARING GUIDE • 2 FLUTE

Tool No.	Cutting Dia.	Each Radius	Cutting Length	Shank Dia.	Overall Length
54186	1-1/4	3/16	1	1/2	2-7/8

Replacement bearing for #54186 use #47706.

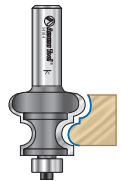

CORNER BEADING BITS

WITH BALL BEARING GUIDE • 2 FLUTE

Tool No.	Cutting Radius	Each Radius	Cutting Length	Shank Dia.	Overall Length	
54160	1/8	7/8	1/4	9/16	1/4	2-1/8
54162	1/8	7/8	1/4	9/16	1/2	2-1/2

Replacement bearing for #'s 54160 & 54162 use #47706.

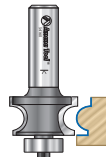

CONVEX EDGING BITS

2 FLUTE

Tool No.	Cutting Dia.	Radius	Large Radius	Cutting Length	Shank Dia.	Overall Length
51580	13/16	23/32	27/32	1-1/4	1/4	2-1/2
51582	13/16	23/32	27/32	1-1/4	1/2	2-3/4

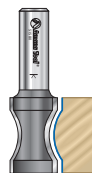

DRAWING LINE BITS

WITH BALL BEARING GUIDE • 2 FLUTE

Tool No.	Cutting Dia.	Radius	Large Radius	Cutting Length	Shank Dia.	Overall Length
54350	1	3/32	3/32	7/8	1/2	2-3/4
54354	1	5/32	5/32	7/8	1/2	2-3/4

Replacement bearing #47716.



CLASSICAL BEAD & COVE BITS

WITH BALL BEARING GUIDE • 2 FLUTE

Tool No.	Cutting Dia.	Each Radius	Cutting Length	Shank Dia.	Overall Length
54100	2	11/32	1-1/4	1/2	3-1/8
54135	2	3/8	1	1/2	2-3/4
54292	1-1/2	3/16 & 5/16	5/8	1/2	2-1/2

Replacement bearing #47706.

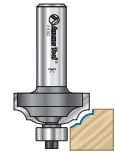

OGEE FILLET BITS

WITH BALL BEARING GUIDE • 2 FLUTE

Tool No.	Cutting Dia.	Each Radius	Cutting Length	Shank Dia.	Overall Length
54127	2-1/4	3/8	15/16	1/2	2-7/8
54110	1-3/8	5/32	1/2	1/4	2-1/16

Replacement bearing #47706.



'LEAF-EDGE' BEADING BITS

WITH DOUBLE BALL BEARING GUIDES • 2 FLUTE

Tool No.	Cutting Dia.	Each Radius	Cutting Length	Shank Dia.	Overall Length
54190	1	3/16	1/2	1/4	2-1/2

Replacement bearings #47712 (2 required).
Replacement collar #47724.



TRIPLE BEADING BIT

WITH BALL BEARING GUIDE • 2 FLUTE

Tool No.	Cutting Dia.	Each Radius	Cutting Length	Shank Dia.	Overall Length
54213	7/8	1/8	1	1/2	3

Replacement bearings #47716.

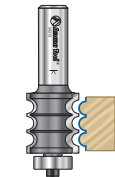

TRIPLE FLUTING BIT

WITH BALL BEARING GUIDE • 2 FLUTE

Tool No.	Cutting Dia.	Each Radius	Cutting Length	Shank Dia.	Overall Length
54217	7/8	1/8	1	1/2	3

Replacement bearings #47716.

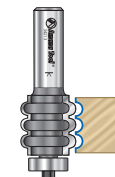

EDGE FLUTING BIT

WITH BALL BEARING GUIDE • 2 FLUTE

Tool No.	Cutting Dia.	Radius	Depth of Cut	Cutting Length	Shank Dia.	Overall Length
54302	3/4	5/16	1/8	1/2	1/2	2-3/4
54306	7/8	3/4	3/16	1	1/2	3-1/4

Replacement bearing #47706.

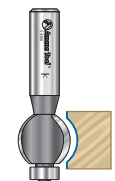



Kitchens

Doors

Kitchen Accessories

Hinges

Drawer Slides

Plywood Melamine

Veneer Edgebanding

Laminate

Solid Surface

Closets

Furniture Hardware

Pulls & Knobs

Lighting

Grommets

Locks, Lock Systems

Molding, Carvings

Tools

Adhesives Solvents Abrasives

Chemicals Staples Screws

BALL END BITS 2 FLUTE

Tool No.	Small Dia.	Large Dia.	Radius	Shank Dia.	Overall Length
45960	1/2	1/4	1/4	1/2	2-1/4
45964	3/4	5/16	3/8	1/2	2-1/2

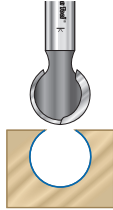

BOWL & TRAY BITS 2 FLUTE

Tool No.	Cutting Dia.	Radius	Cutting Length	Shank Dia.	Overall Length
45982	3/4	1/4	5/8	1/4	2-5/8
45984	3/4	1/4	5/8	1/2	2-5/8
45986	1-1/8	1/4	5/8	1/2	2-5/8

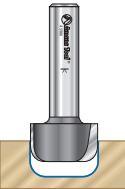

BULLNOSE/COVE EDGE BITS WITH BALL BEARING GUIDE • 2 FLUTE

Tool No.	Cutting Dia.	Radius 1	Radius 2	Cutting Length	Shank Dia.	Overall Length
51530	1-1/8	1/8	1/4	1	1/2	2-7/8
51534	1-3/8	3/16	1/2	1-9/16	1/2	3-3/8

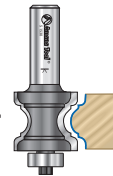

Replacement bearing #47716.

CLASSICAL OGEE BIT WITH BALL BEARING GUIDE • 2 FLUTE

Tool No.	Cutting Dia.	Radius 1	Radius 2	Cutting Length	Shank Dia.	Overall Length
54292	1-1/2	3/16	5/16	5/8	1/2	2-1/2

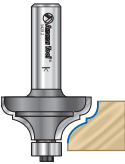

Replacement bearing #47706.

HANDRAIL/TABLE EDGE BITS WITH BALL BEARING GUIDE • 2 FLUTE

Tool No.	Cutting Dia.	Radius 1	Radius 2	Cutting Length	Shank Dia.	Overall Length
16 49550	2-3/4	1-3/4	5/8	1/2	1/2	2-1/2
16 49554	2-1/2	3/8	3/4	1/2	1/2	2-3/4
16 49556	2-1/2	3/8	3/4	1/2	1/2	2-3/4



Replacement bearing #47706.

'DECO' DOOR EDGE DETAIL BITS 1/2" SHANK • 2 FLUTE

Tool No.	Cutting Dia.	Radius 1	Radius 2	Cutting Length	Overall Length
53820	2	3/8	1/8	1-3/16	2-1/2
49562	1-3/4	3/8	3/8	11/16	2-5/8

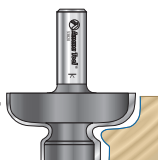

Replacement bearing #47706 for Tool #49562.

LANSEN™ EDGE SINK BITS

WITH ULTRA-GLIDE™ BALL BEARING GUIDE • 2 FLUTE
Seamless Integration with Lansen Edge Sinks™

NEW

Tool No.	Pattern	Cutting Dia.	Cutting Length	Shank Dia.	Overall Length
57169	Bevel	1-3/16	1	1/2	3-1/8
57155	Flush	49/64	1-1/2	1/2	3-1/2
49409	Bevel	7/8	3/4	1/2	2-1/4



Ultra-Glide™ Delrin® Ball Bearing # 47733 (fits #57169 & #57155)

Steel Ball Bearing #47718 (fits #49409)

UNDERMOUNT BOWL SOLID SURFACE BITS WITH ULTRA-GLIDE™ BALL BEARING GUIDE • 2 FLUTE

Tool No.	Cutting Dia.	Type	Angle	Cutting Length	Radius	Overall Length
57122	1-1/4	Bevel	10°	15/16	--	2-7/8
57128	2-1/8	Round	18°	1	1/2	3
57130	2-5/8	Round	18°	1-1/4	9/16	3-1/4



Replacement 'Ultra-Guide™' bearing #47726.

ROUND UNDER SOLID SURFACE BITS WITH ULTRA-GLIDE™ BALL BEARING GUIDE • 2 FLUTE

Tool No.	Cutting Dia.	Radius	Cutting Length	Shank Dia.	Overall Length
57138	2-1/8	1/2	3/4	1/2	2-7/8
57140	2-5/8	3/4	1	1/2	3

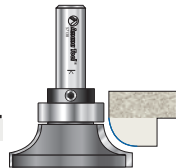

Replacement 'Ultra-Guide™' bearing #47737 (after 6/95).
Replacement steel bearing #47738 (prior to 6/95).
Replacement collar #47740.



REPLACEMENT KNIFE SYSTEM CNC ENGRAVING & LETTERING

Tool No.	Shank Dia.
RC-1075	1/4
RC-1076	1/2

Replacement Insert Knives available in:
V-Tips - 30°, 60° and 90° - 18 sizes
Straight - 4 sizes
Core Box - 4 sizes
Corner Round & Bead Groove - 3 sizes



⚠ Warning: Maximum RPM ⚠₁₀ = 10,000; ⚠₁₂ = 12,000; ⚠₁₄ = 14,000; ⚠₁₆ = 16,000; ⚠₁₈ = 18,000; ⚠₂₀ = 20,000; ⚠₂₂ = 22,000



Heavy Wire Staplers

It's fast, multi-directional stitching is a major benefit in applications like ridge beams and all types of sheathing.

- Durable construction, minimizes downtime and operating costs
- Adjustable depth of drive
- EZ-Clear latch
- Comfort grip handle
- Reload indicator

Galvanized Staples for SENC0 3L0003N

Item Code	Length	Gauge	Crown	Point	Finish	Coating	Carton Count
65-N13VAV	1	16	7/16"	Chisel	Bright Basic	Sencote	5M
65-N15VAV	1 1/4	16	7/16"	Chisel	Bright Basic	Sencote	10M
65-N17VAV	1 1/2	16	7/16"	Chisel	Galvanized	Sencote	10M
65-N21VAV	2	16	7/16"	Chisel	Galvanized	Sencote	10M



ORDER NUMBER

3L0003N.....65-158

Medium Wire Staplers

SLP20XP

H: 8-1/4" L: 9-1/2" W: 2.3 lbs. Capacity: 110

The ergonomically designed SLS20XP increases quality and productivity in a wide variety of applications.

- Ultra-Light (2.5 Lbs.) For Ease Of Handling
- Neverlube® Design Means Easier Maintenance
- No Lubrication To Stain Fine Wood
- Ergonomically Designed With Comfort Grip
- Adjustable Depth Of Drive
- No-Mar Pad

Galvanized Staples for SENC0 SKSXP

Item Code	Length	Gauge	Crown	Point	Finish	Coating	Carton Count
65-M10BABN	5/8"	18	3/8"	Chisel	Bright Basic	Sencote	5M
65-M11BABN	3/4"	18	3/8"	Chisel	Bright Basic	Sencote	5M
65-M06BABN	3/8"	18	3/8"	Chisel	Galvanized	Sencote	10M
65-M08BAB	1/2"	18	3/8"	Chisel	Galvanized	Sencote	10M
65-M12BAB	7/8"	18	3/8"	Chisel	Galvanized	Sencote	5M



ORDER NUMBER

SLS20XP.....65-101

Powerplus® SKSXP

SKSXP is available for use in a wide variety of wood-working applications. It is offered in 16 and 18 gauge and 3 different crown widths in staple lengths up to 1 1/2".

- E-Z LOAD, Ez-Clear System
- Only 2 Moving O-Rings - Less Maintenance
- Quiet Operation
- Long 1" Lip To Get Into Tight Spots
- Nevellube® Design

Galvanized Staples for SENC0 SLS20XP-L

Item Code	Length	Gauge	Crown	Point	Finish	Coating	Carton Count
65-L10BABN	5/8"	18	1/4"	Chisel	Galvanized	Sencote	5M
65-L11BAB	3/4"	18	1/4"	Chisel	Galvanized	Sencote	5M
65-L13BABN	1"	18	1/4"	Chisel	Galvanized	Sencote	5M
65-L14BAB	1 1/8"	18	1/4"	Chisel	Galvanized	Sencote	5M
65-L15BAB	1 1/4"	18	1/4"	Chisel	Galvanized	Sencote	5M
65-L17BAB	1 1/2"	18	1/4"	Chisel	Galvanized	Sencote	5M



ORDER NUMBERS

Powerplus® SKSXP65-106
Powerplus® SLS20XP.....65-103

- Kitchens
- Doors
- Kitchen Accessories
- Hinges
- Drawer Slides
- Plywood Melamine
- Veneer Edgbanding

- Laminate
- Solid Surface
- Closets
- Furniture Hardware
- Pulls & Knobs
- Lighting
- Grommets

- Locks, Lock Systems
- Molding, Carvings

- Tools
- Adhesives Solvents Abrasives
- Chemicals Staples Screws

Medium Wire Staplers

SLP20XP

Kitchens

H: 8-1/4"

L: 9-1/2"

W: 2.3 lbs.

Capacity: 110

The SLP20XP design ensures unmatched ease of use as well as superior precision and driving power, which makes this tool perfect for fastening a variety of material types and thicknesses.

- Drives Both Slight And Medium Head Brads
- Requires Minimum Maintenance For Trouble-Free Upkeep
- Muffler Ensures Quieter Operation
- Neverlube® Design
- Includes Case



ORDER NUMBER

SLP20XP.....65-100

Applications

Beading, Cabinets, Chair Rail, Decorative Trim, Furniture, Molding, Paneling, Picture Frames, Rattan, Scribe Molding, Upholstery



Galvanized Staples for the Senco SLS20L

	Item Code	Length	Head	Point	Coating	Carton Count
Drawer Slides	65-AZ08EAA	1/2"	Headless	Chisel	Plain	5M
	65-AZ11EAA	3/4"	Headless	Chisel	Plain	5M
Plywood Melamine	65-AZ13EAA	1"	Headless	Chisel	Plain	5M
	65-AY10EAA	5/8"	Slight	Chisel	Plain	5M
Veneer Edgebanding	65-AY11EAA	3/4"	Slight	Chisel	Plain	5M
	65-AY13EAA	1"	Slight	Chisel	Plain	5M
Laminate	65-AX10EAA	5/8"	Medium	Chisel	Plain	5M
	65-AX11EAA	3/4"	Medium	Chisel	Plain	5M
	65-AX13EAA	1"	Medium	Chisel	Plain	5M
Solid Surface	65-AX15EAA	1 1/4"	Medium	Chisel	Plain	5M
	65-AX17EAA	1 1/2"	Medium	Chisel	Plain	5M
Closets	65-AX18EAA	1 5/8"	Medium	Chisel	Plain	5M
	65-AX19EAA	1 3/4"	Medium	Chisel	Plain	5M
Furniture Hardware	65-AX21EAA	2"	Medium	Chisel	Plain	5M
	65-AX22EAA	2 1/8"	Medium	Chisel	Plain	5M

Micro Pinner

H: 6-1/2"

L: 8-1/2"

W: 2.25 lbs.

Engineered for pros and demanding work environments at competitive pricing

Applications

Ideal for carving and ornamentals, toy building, cabinet doors, small trim, picture frames, glazing bead, bird houses, bee hive assembly

Benefits

- Rear exhaust directs oil and dust away from wood surfaces
- Metal magazine for durability
- Soft handle grip
- Easy fastener length adjustment
- Visible fastener LOAD and RELOAD indicator
- Includes fittings, wrenches, and oil



ORDER NUMBER

Finish Pro™ 10 65-146

Headless Pins for the Senco Finish Pro™ 10

ORDER NUMBER	GAUGE	PIN TYPE	PIN LENGTH	PIECES PER BOX
65-A100509	23	Micro Pin	1/2"	2.6M
65-A100629	23	Micro Pin	5/8"	2.6M
65-A100759	23	Micro Pin	3/4"	2.6M
65-A101009	23	Micro Pin	1"	2.6M
65-A109809	23	Micro Pin	Variety Pack*	2.6M

*Variety Pack includes 600 each of 1/2", 5/8", 3/4", 1"

Tools



Corrugated Fastener Tool

H: 9-1/4" L: 12-11/16" W: 6.9 lbs. Capacity: 106

Corrugated fastener provides twice the strength of ordinary fasteners

Applications

Butt Joints in Cabinets and Furniture, Frames, Door and Window Sash, Millwork, Truss Construction, Picture Frames, Wood boxes, Pallet Stringer Repair

Benefits

- Added strength for larger butt joints
- Powerful for hard and dense material



Galvanized Corrugated Fasteners (5M/box)

ORDER NUMBER	GAUGE	CROWN WIDTH	STAPLE LENGTH	SENCO REFERENCE
65-X06NRA	25	1"	3/8"	X06

ORDER NUMBER
Senco SC2..... 65-112

- Kitchens
- Doors
- Kitchen Accessories
- Hinges
- Drawer Slides
- Plywood Melamine
- Veneer Edgebanding



Fine Wire Staplers

H: 5-15/16" L: 9-1/2" W: 2 lbs. Capacity: 110-185

Powerful finish and trim stapler designed for easy handling and virtually trouble-free maintenance

Applications

Furniture, Upholstering, Automotive Vinyl and Interior Trim, Home Insulation, Dust covers, TV and Stereo Grille Cloth, Picture Frames, Case backs, Shoe making, Roofing Felt, Felt Insulation, Decorative Trim and Molding

Benefits

- Lightweight (1.7 lbs.) well balanced and easy to handle
- Neverlube™ Design means no oil to damage the work surface
- Sencomatic® rapid-fire models and double length magazines available special order



Galvanized Staples for SENCO SFW10 Models

Item Code	Length	Gauge	Crown	Point	Finish	Coating	Carton Count
65-A06BABN	3/8"	22	3/16"	Chisel	Galvanized	Sencote	30M
65-A08BAB	1/2"	22	3/16"	Chisel	Galvanized	Sencote	20M
65-D10BABN	5/8"	22	3/16"	Chisel	Galvanized	Sencote	20M
65-C04BAAP	1/4"	22	3/8"	Chisel	Galvanized	Plain	35M
65-C06BAAP	3/8"	22	3/8"	Chisel	Galvanized	Plain	50M
65-C08BAAP	1/2"	22	3/8"	Chisel	Galvanized	Plain	35M
65-C10BAAP	5/8"	22	3/8"	Chisel	Galvanized	Plain	27M

* SPECIAL ORDER *

ORDER NUMBERS
SFW10XP-A (3/16 Crown)..... 65-121
SFW10XP-C (3/8 Crown)..... 65-125

- Laminate
- Solid Surface
- Closets
- Furniture Hardware
- Pulls & Knobs
- Lighting
- Grommets
- Locks, Lock Systems
- Molding, Carvings
- Tools
- Adhesives Solvents Abrasives
- Chemicals Staples Screws

Brad Nailer / Compressor Kit

FinishPro18 Brad Nailer / Compressor kit has Everything to get you started on the job. The FinishPro® 18 Brad Nailer is a versatile nailer for all your finish needs. The SENCO® PC1010 Compressor is a 1-gallon, oil-less portable air compressor. Its lightweight, rugged design will satisfy the needs of the professional.



Applications

Cabinets, Casebacks, Drawers, Upholstery, Spring Attachment, Insulative Sheathing, Underlayment, Soffits, Molding and Trim, Latic, Hardwood Floors

Brad Nailer / Compressor Kit Features:

FinishPro® 18 Brad Nailer

- Adjustable depth-of-drive control
- Adjustable exhaust
- Belt hook, comfort grip and no-mar pad
- Lightweight and powerful
- 1 Gallon Electric Hand-Carry Compressor

1 HP (peak) and 1/2 HP (running) oil-less motor

- 1-gallon capacity tank
- 4 Amps at 115 Volt with 120 PSIG maximum output
- 1/4" quick disconnect coupler
- Individual gauges for tank and regulated output pressure
- Hand carry

Includes:

- FinishPro® 18 Brad Nailer
- 1 Gallon Electric Hand-Carry Compressor
- PC0947, FinishPro® 18 Gauge Brad Nailer Compressor Combo Kit - PC0947
- 1/4" x 25' Coil Hose
- Tool Oil
- All Necessary Air Fittings
- Safety Glasses
- Manuals
- Variety Pack of 18-Gauge Brad Nails

ORDER NUMBER

Finish Pro™ Brad Nailer Kit..... **65-160**

*Special Order

Specifications:

- FinishPro® 18 Brad Nailer
- Fastener Range: 5/8" - 2"
- Height: 9.3"
- Length: 9-3/4"
- Regular Operating Pressure: 70 - 95 PSIG (4.8 - 6.5 bar)
- Mode Of Operation: Contact Actuation
- Air Inlet: 1/4" NPT
- Gauge: 18-Gauge
- Fastener Capacity: 110

1 Gallon Electric Hand-Carry Compressor

- Power Source: Electric
- Maximum Amperage: 4 Amps @ 115 Volt
- Horsepower: 1 HP (Peak); 0.5 HP (Running)
- Pump: Oil-Less
- Air Flow: .7 SCFM
- Pump-Up Time: 128 Seconds (0 - 120 PSI)
- Recovery Time: 35 Seconds (90 - 120 PSI)
- Maximum Pressure: 120 PSI
- Tank Storage: 1-Gallon
- Dimensions: 14" x 10" x 13" (L x W x H)

Kitchens

Doors

Kitchen Accessories

Hinges

Drawer Slides

Plywood Melamine

Veneer Edgbanding

Laminate

Solid Surface

Closets

Furniture Hardware

Pulls & Knobs

Lighting

Grommets

Locks, Lock Systems

Molding, Carvings

Tools

Adhesives Solvents Abrasives

Chemicals Staples Screws



Brad Nailer / Compressor Kit

The SENCOR[®] PC1010 Compressor is a 1/2 HP, 1-gallon, oil-less portable air compressor. Its lightweight, rugged design will satisfy the needs of the professional! This lightweight micro pinner is the perfect tool for all of your intricate finish and trim remodeling projects. The micro pins fasten the smallest of decorative trim securely and leave a nearly invisible hole with no splitting or puttying. The FinishPro 10 drives 1/2" - 1" 23-gauge micro pins.

Applications

Cabinets, Casebacks, Drawers, Upholstery, Spring Attachment, Insulative Sheathing, Underlayment, Soffits, Molding and Trim, Latic, Hardwood Floors

Pin Nailer / Compressor Kit Features:

- FinishPro[®] 10 Micro Pinner
- Easy fastener length adjustment
- Hardened alloy steel driver for durability
- Rear exhaust
- Smooth metal cap and magazine
- Soft grip for comfort and control
- Extra power for use in hardwoods
- Low LOAD indicator
- Heavy-duty body

Compressor

- 1 HP (peak) and 1/2 HP (running) oil-less motor
- 1-gallon capacity aluminum tank
- 4 Amps at 115 Volt with 120 PSIG maximum output
- 1/4" quick disconnect coupler and regulator
- Individual tank gauges to regulate output pressure
- Hand carry cushioned grip handle
- Lightweight at only 20 lbs., yet compact, rugged and designed for the professional

FinishPro 10 Combo Kit Includes:

- FinishPro[®] 10 Micro Pinner - 2C0001N
- 1 Gallon Electric Hand-Carry Compressor - PC1010
- PC0974, FinishPro[®] Micro Pinner and Compressor Combo Kit - PC0974
- 1/4" x 25' Recoil Air Hose
- Tool Oil
- All Necessary Air Fittings
- Safety Glasses
- Manuals
- Variety Pack of Headless Pins
- Tool Case



ORDER NUMBER

Finish Pro[™] Pin Nailer Kit.....**65-176**

*Special Order

Specifications:

- FinishPro[®] 10 Micro Pinner
- Fasteners Used: 1/2" - 1"
- Height: 6 3/4" (171 mm)
- Length: 8-7/8" (225mm)
- Regular Operating Pressure: 70 - 95 PSIG (4.8 - 6.5 bar)
- Mode Of Operation: Sequential Actuation
- Lip Length: 5/8"
- Gauge: 23-Gauge
- Pin Capacity: 110

1 Gallon Electric Hand-Carry Compressor

- Power Source: Electric
- Maximum Amperage: 4 Amps @ 115 Volt
- Horsepower: 1 HP (Peak); 0.5 HP (Running)
- Pump: Oil-Less
- Air Flow: .7 SCFM
- Pump-Up Time: 128 Seconds (0 - 120 PSI)
- Recovery Time: 35 Seconds (90 - 120 PSI)
- Maximum Pressure: 120 PSI
- Tank Storage: 1-Gallon
- Dimensions: 14" x 10" x 13" (L x W x H)

Kitchens

Doors

Kitchen Accessories

Hinges

Drawer Slides

Plywood Melamine

Veneer Edgebanding

Laminate

Solid Surface

Closets

Furniture Hardware

Pulls & Knobs

Lighting

Grommets

Locks, Lock Systems

Molding, Carvings

Tools

Adhesives Solvents Abrasives

Chemicals Staples Screws

Tools

TAPE MEASURE

by FastCap™

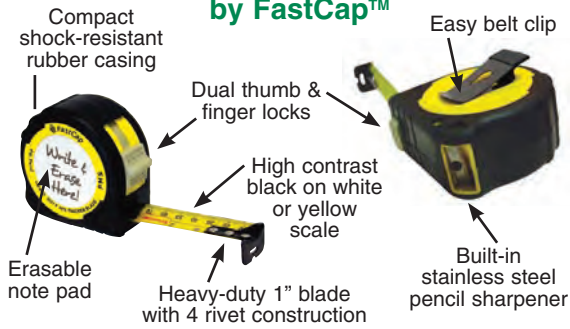

ORDER NUMBERS

PMS 16' Metric Standard**20-116**
 PMS 25' Metric Standard**20-118**
 PS 16' Standard**20-120**
 PS 25' Standard**20-122**

3M MASKING TAPE



ORDER NUMBERS

3/4"**47-138**
 2"**47-140**

PAINT BRUSHES



ORDER NUMBERS

1"**47-184**
 2"**47-186**
 3"**47-188**

J-ROLLER



ORDER NUMBER
47-110

TRIPLE ROLLER



ORDER NUMBER
47-256

ROLLER FRAMES

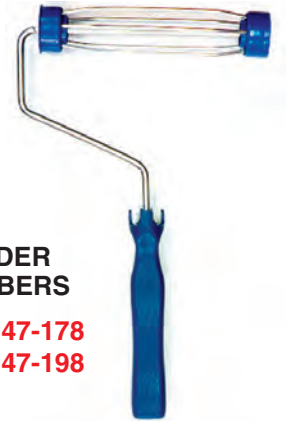

ORDER NUMBERS

3"**47-178**
 9"**47-198**

100% COTTON RAGS

10 lb. Box
 ORDER NUMBER
47-802



TRIM EASE

ORDER NUMBER
47-154



ROLLER COVERS

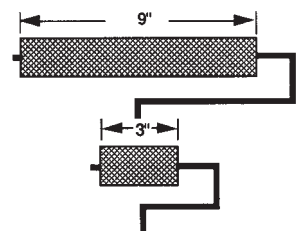

ORDER NUMBERS

3"**47-114**
 9"**47-116**

Kitchens

Doors

Kitchen Accessories

Hinges

Drawer Slides

Plywood Melamine

Veneer Edgebanding

Laminate

Solid Surface

Closets

Furniture Hardware

Pulls & Knobs

Lighting

Grommets

Locks, Lock Systems

Molding, Carvings

Tools

Adhesives Solvents Abrasives

Chemicals Staples Screws

Tools

PLASTI-CUT FILES

ULTRA SHARP • ULTRA HARD



For fast, clean cuts and long economical life.
Designed especially for decorative laminates. (box of 5)

ORDER NUMBERS

12" Fast file.....	47-102	10" Mill file	47-100
14" Fast file.....	47-106	12" Mill file	47-104
14" Fast file.....	47-106	14" Mill file	47-108

FILE BRUSH

UNCLOGS YOUR FILES FOR FASTER, CLEANER CUTTING



ORDER NUMBER
47-112

Mercer Dual File

**DOUBLE CUT ON ONE SIDE FOR FASTER CUTTING,
SINGLE CUT ON THE OTHER FOR A MORE PRECISE CUT.**



ORDER NUMBERS 10" - 12 pack**47-310**
INDIVIDUAL SLEEVES INCLUDED 12" - 6 pack**47-312**

Mercer FastMill File

SINGLE CUT (FAST) BOTH SIDES



ORDER NUMBERS 10" - 12 pack**47-320**
INDIVIDUAL SLEEVES INCLUDED 12" - 6 pack**47-322**

Mercer Rapid Cross Cut File

DOUBLE CUT BOTH SIDES / FASTEST CUT AVAILABLE



ORDER NUMBERS 10" - 12 pack**47-330**
INDIVIDUAL SLEEVES INCLUDED 12" - 6 pack**47-332**

TriBlade by FastCap™

NEVER BE WITHOUT A SHARP KNIFE AGAIN!

- Comfortable, rubber grip
- Retractable, auto-locking snap-off blade
- Blade storage in knife



ORDER NUMBERS
TriBlade Utility Knife**20-124**
Replacement Blades - 10 Pack.....**20-126**

QWIK-SET HARDWARE Pull JIG

FOR DOORS AND DRAWERS

This very handy and practical jig is ideal for the small to medium size shop, and use in the field.

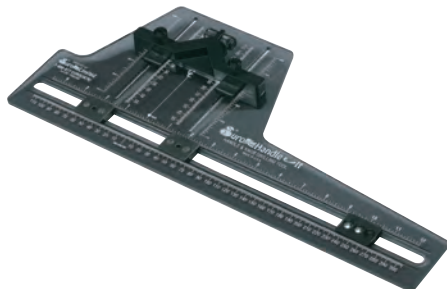

ORDER NUMBER
47-210

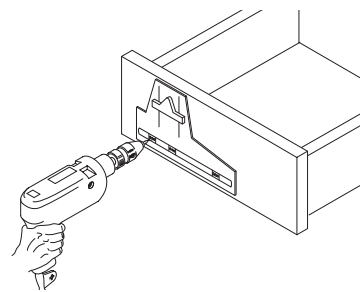

Use a 4.5mm or 3/16" drill

- Kitchens
- Doors
- Kitchen Accessories
- Hinges
- Drawer Slides
- Plywood Melamine
- Veneer Edgebanding
- Laminate
- Solid Surface
- Closets
- Furniture Hardware
- Pulls & Knobs
- Lighting
- Grommets
- Locks, Lock Systems
- Molding, Carvings
- Tools
- Adhesives Solvents Abrasives
- Chemicals Staples Screws

Most of the merchandise in this catalog is available in all Hardware Imagination-Tech locations. If your selection isn't available at the store nearest you, we'll gladly order it from one of the other stores or through special order.

Cap Covers

Kitchens

Doors

Kitchen Accessories

Hinges

Drawer Slides

Plywood Melamine

Veneer Edgebanding

Laminate

Solid Surface

Closets

Furniture Hardware

Pulls & Knobs

Lighting

Grommets

Locks, Lock Systems

Molding, Carvings

Tools

Adhesives Solvents Abrasives

Chemicals Staples Screws

Cover Caps

Cover caps by FastCap are self adhesive caps made of durable PVC or unfinished/prefinished real wood veneers. It is available for a wide variety of applications from covering RTA fittings to trimming out plumbing cut outs in sink cabinets.

Take this cap & stick it!



US.Pat.No. 5,997,229



ProOrganizer

- Rugged and durable PVC
- Holds 10 different colors and up to 5 sheets per section
- Accordion style organization
- Includes tabs for easy labeling
- Prefilled Organizer comes with our 10 most popular colors



Description	Order Number
ProOrganizer (pre-filled)	20-130

Edgebanding



NO More Ironing!



works! Fastedge is the perfect solution for field repairs, inside and outside radiuses, scribe tape, and countless other applications. Durable and easy to use, Fastedge is made from high quality PVC and real wood veneers. Our high performance pressure sensitive acrylic adhesive increases in strength as it cures, providing a long lasting, permanent bond.



Description	Order Number
White PVC 15/16" x 50' Roll Fastedge	20-132
Maple Prefinished 15/16" x 50' Roll Fastedge	20-134
Cherry Prefinished 15/16" x 50' Roll Fastedge	20-136
Oak Prefinished 15/16" x 50' Roll Fastedge	20-138
Maple Unfinished 15/16" x 50' Roll Fastedge	20-140
Cherry Unfinished 15/16" x 50' Roll Fastedge	20-142
Oak Unfinished 15/16" x 50' Roll Fastedge	20-144

Cap Covers



Caps for Plumbing

5 sheets per box.
10 for 1/2" Supply Line and
5 for 1-7/8" Waste Line
covers.

5/8"
16mm
For 1/2"
Supply Line

1-7/8"
49 mm
For 1-1/2" Waste Line

Unfinished

Unfinished wood veneer caps that can be sanded and stained to match any finish requirements.

Packaged 260 caps - 5 caps per sheet - 5 sheets per box.

red oak 19-958	pine N.S.	ash 19-968
white oak N.S.	white birch 19-966	hickory 19-970
maple 19-960	natural birch N.S.	sapele 19-972
cherry 19-962	walnut N.S.	pecan N.S.
mahogany 19-964	VG Fir N.S.	teak N.S.
	anigre 19-967	alder N.S.

Unfinished Real Wood Sampler Pack

16 sheets: 1 sheet of each
Unfinished Real Wood color
Order #: 19-992

PVC

white 19-920	renaissance oak 19-934	clear maple N.S.	autumn cherry N.S.	knotty pine 19-956
antique white 19-921	pickled oak 19-936	american maple N.S.	fuji cherry N.S.	beech N.S.
almond 19-922	rosewood oak 19-938	natural cherry 19-950	red mahogany 19-946	finished MDF N.S.
black 19-924	medium oak N.S.	select cherry 19-954	dark red mahogany 19-948	brushed brass N.S.
fog gray 19-926	light oak N.S.	medium cherry 19-952	presidential walnut N.S.	polished brass N.S.
folkstone gray 19-928	hardrock maple 19-940	bourbon cherry N.S.	imperial walnut N.S.	brushed chrome N.S.
natural oak 19-930	manitoba maple 19-942	golden cherry N.S.	mahogany on walnut N.S.	polished chrome N.S.
golden oak 19-932	white washed maple 19-944	dark cherry N.S.		
	light maple 19-945	heritage cherry N.S.		

PVC Sampler Pack
41 sheets: 1 sheet of each
Solid/Woodgrained PVC
& Metallics

Order #: 19-990

- Kitchens
- Doors
- Kitchen Accessories
- Hinges
- Drawer Slides
- Plywood Melamine
- Veneer Edgebanding
- Laminate
- Solid Surface
- Closets
- Furniture Hardware
- Pulls & Knobs
- Lighting
- Grommets
- Locks, Lock Systems
- Molding, Carvings
- Tools
- Adhesives Solvents Abrasives
- Chemicals Staples Screws

Cap Covers

Kitchens

Doors

Kitchen Accessories

Hinges

Drawer Slides

Plywood Melamine

Veneer Edgbanding

Laminate

Solid Surface

Closets

Furniture Hardware

Pulls & Knobs

Lighting

Grommets

Locks, Lock Systems

Molding, Carvings

Tools

Adhesives Solvents Abrasives

Chemicals Staples Screws

2P-10 Adhesive Systems

With 2P-10 you can easily glue the hardest joints in cabinetry without clamping.



Description	Order Number
2P-10 Activator - 2 oz.	20-146
2P-10 Medium Adhesive - 1 oz.	20-100
2P-10 Jël Adhesive - 1 oz.	20-102
2P-10 Solo Activator - 12 oz.	20-104
2P-10 Jël Adhesive - 8 oz.	20-106



TriBlade

Never be without a sharp knife again!

- Comfortable, rubber grip
- Retractable, auto-locking snap-off blade
- Convenient blade storage in knife



Description	Order Number
TriBlade Utility Knife	20-124
Replacement Blades - 10 Pack	20-126

pro carpenter professional tape measure

Tape measures have evolved to the next level... The heavy-duty ProCarpenter Series features an erasable note pad, pencil sharpener, rugged rubberized case and a super thick one inch wide blade. Rated by *American Woodworker* as "genius" and Best New Tool of 2004 (the PS-SP) these tapes are a practical addition to your toolbox.



Compact shock-resistant rubber casing

Dual thumb & finger locks

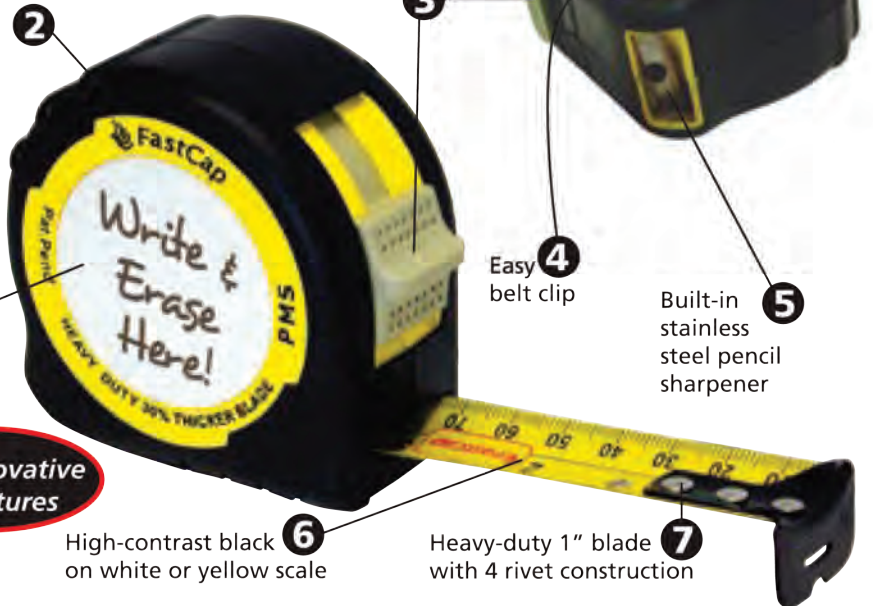

Erasable note pad

Easy belt clip

Built-in stainless steel pencil sharpener

7 Innovative Features

High-contrast black on white or yellow scale

Heavy-duty 1" blade with 4 rivet construction

Description	Part Number
PMS 16' Metric/Standard	20-116
PMS 25' Metric/Standard	20-118
PS 16' Standard	20-120
PS 25' Standard	20-122

Cap Covers

Kitchens

Doors

Kitchen Accessories

Hinges

Drawer Slides

Plywood Melamine

Veneer Edgebanding

Laminate

Solid Surface

Closets

Furniture Hardware

Pulls & Knobs

Lighting

Grommets

Locks, Lock Systems

Molding, Carvings

Tools

Adhesives Solvents Abrasives

Chemicals Staples Screws



3rd Hand HD & Little Hand HD



WARNING!
This product may make your job & life easier.



NEW
Neoprene Comfort Grip!



every 1' for positive locking



NEW
Adjustment!

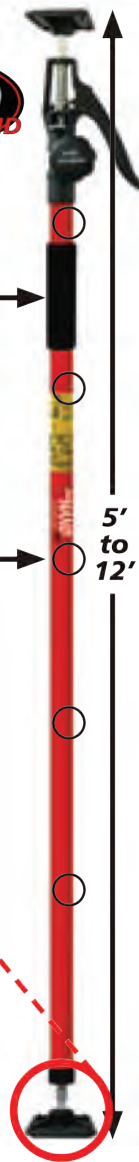

Description	Order Number
3rd Hand HD (5' to 12' extension)	20-110
Little Hand HD (16.5" to 22.8" extension)	20-112
UniversalFOOT	20-114

Cap Covers

SoftWax

Wax Filler System



SoftWax is a great way to fill holes in finished woodwork! The refillable kit comes with 20 blendable colors, a Wax-Wedge and a buffing pad.

Description	Order Number
SoftWax	20-148

Glü-Bot

The Glue Bottle that Sucks!



- No dripping
- Replaceable tips
- Vertical application
- Wide mouth for easy filling
- Wide bottom for extra stability
- Works with most glues and solvents

Description	Order Number
Glü-Bot	20-108

Breeze Tip



Description	Order Number
Breeze Tip 1/2" 10 Pack	20-128