

## Dynapro Drawer Slides

Kitchens

Doors

Kitchen Accessories

Hinges

Drawer Slides

Plywood Melamine

Veneer Edgebanding

Laminate



### Efficient. Effective. Concealed.

Dynapro, the new generation of undermount slides for wood drawers, combines intelligent features plus superb gliding action for today's modern cabinetry

With a drawer slide as technically advanced as the Dynapro, you will find many enhanced features. One example is the ease in which the Dynapro pulls open and naturally the closing action is just as sophisticated with the Grass Softclose system.

Solid Surface

Closets

Furniture Hardware

Pulls & Knobs

Lighting



### Synchronization achieves smooth operation without a sound.

In contrast to conventional undermount slide systems, Dynapro is the only slide that features a synchronization mechanism. This mechanical synchronization of each individual slide ensures enhanced comfort and movement without annoying sounds or resistance. The operating function of Dynapro remains unchanged even when moving heavy loads. Loads of up to 130 pounds present no problem for Dynapro. Abrasion-resistant nylon rollers ensure smooth and even operation.

### 3D adjustment option for perfect alignment: Height adjustment, Side adjustment, and Tilt adjustment.

Dynapro is the first undermount slide system to offer an integrated three-dimensional adjustment option. The drawer can be adjusted vertically, horizontally, and in the tilt angle. Dynapro is the first undermount slide that has incorporated a 3-dimensional adjustment that has long been a standard for drawer systems such as Nova Pro and DWD XP. Adjustments are simple operations and easily performed without the use of tools. In short, it just takes a few tweaks to achieve perfect alignment.

But it's not only the end user who benefits from these technical developments. For installers and cabinet manufacturers, Dynapro's precise drawer front alignment is a plus.

With operating comfort, stability, maximum adjustment, quiet operation, and increased carrying capacity, Dynapro provides what today's cabinet makers and end users want most.

**G\* GRASS**

## Dynapro Drawer Slides

Kitchens

Doors

Kitchen Accessories

Hinges

Drawer Slides

Plywood Melamine

Veneer Edgebanding

Laminate

Solid Surface

Closets

Furniture Hardware

Pulls & Knobs

Lighting

Grommets

Locks, Lock Systems

Molding, Carvings

Tools

Adhesives Solvents Abrasives

Chemicals Staples Screws



- Synchronization for smooth, silent operation
- Ridges on drawer member and front locking devices for immediate connection
- Support roller for uniform drawer front height
- 3-D adjustment - tilt, height, and side - is simple, tool free and easily accessible
- Easy to open with a low pull-out force
- Wide drawer member provides stability between cabinet and drawer member

- Uniform height position of drawer front panel regardless of weight due to the support roller.



- Ridges on the slide and front locking device connect immediately at installation for maximum connection between the drawer slide and front locking device.
- Excellent running performance due to the world's first synchronization in Concealed drawer slides.

### Dynapro Application

- For drawer material up to 5/8" (16 mm)
- For frameless or face frame application
- Use rear socket for face frame application
- Heavy duty slide must be blocked out for face frame application

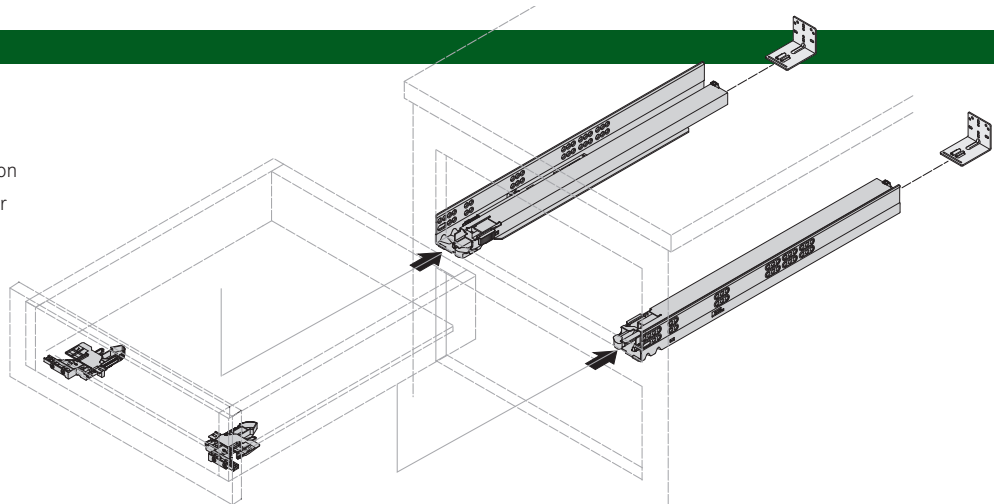

### Inserting the drawer

Place drawer on extended Dynapro slide and push in until it engages audibly

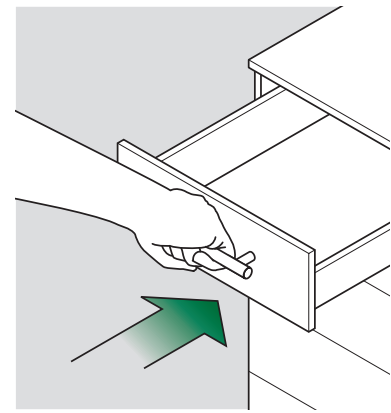
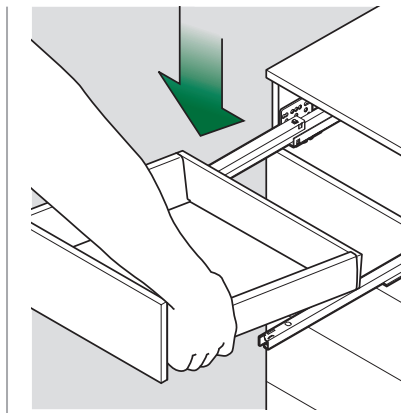

**G\*GRASS**

## Dynapro Drawer Slides

Kitchens

Doors

Kitchen Accessories

Hinges

Drawer Slides

Plywood Melamine

Veneer Edgebanding

Laminate

Solid Surface

Closets

Furniture Hardware

Pulls & Knobs

Lighting

Grommets

Locks, Lock Systems

Molding, Carvings

Tools

Adhesives Solvents Abrasives

Chemicals Staples Screws



- **Frameless Application**
- Full extension with a synchronized mechanism
- Soft-close damping system
- Maximum connection to drawer slide and front locking device
- Integrated 2-dimensional adjustment for alignment (2-D)
- Integrated 3-dimensional adjustment for alignment (3-D)
- Height adjustment + 3.5 mm
- Side adjustment ± 1.5 mm
- 88 lbs. LOAD rating (40 kg)
- For 5/8" (16 mm) drawer material



### 2-D FRAMELESS ORDER NUMBERS

229 mm (9")	.....	<b>25-912A</b>
305 mm (12")	.....	<b>25-914A</b>
381 mm (15")	.....	<b>25-916A</b>
457 mm (18")	.....	<b>25-918A</b>
533 mm (21")	.....	<b>25-920A</b>

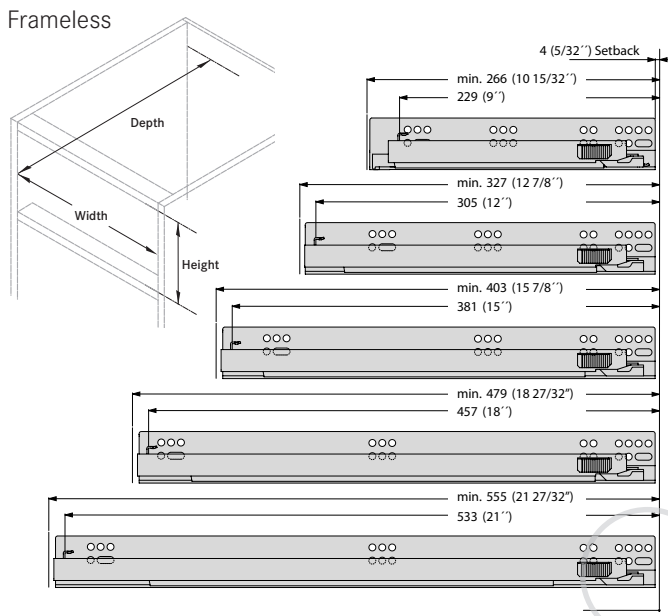

1. Determine the interior cabinet depth and choose the right slide. Measure from outside of the face frame or outside of the side panel to the cabinet back / cross stretcher. Refer to the charts below to choose the correct face frame or frameless slide. Drawer box length will correspond.
2. Prepare your drawer box
  - A Calculate the outside drawer box width  
Example: When using 16 mm (5/8") drawer material, the formula is: Inside cabinet width minus 10 mm (3/8")
  - B The drawer bottom reveal is 10 mm (3/8") to 13 mm (1/2") deep.
  - C Drawer back notch = 35 mm (1 3/8")
3. Layout your cabinet

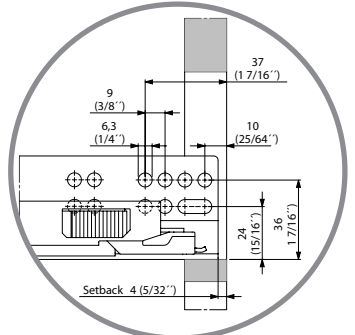
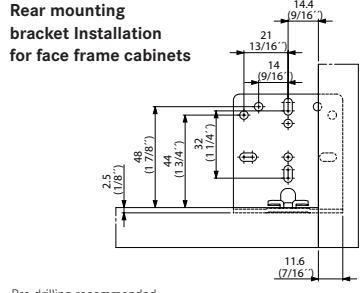
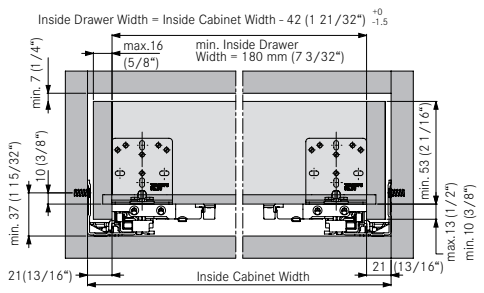

Pre-drilling recommended  
Ø2.5 mm (3/32")

### Front locking device

- For 2-dimensional and 3-dimensional drawers
- For standard width drawers
- For standard width inset drawers
- Minimum inside drawer width 180 (7 3/32")

Pre-drilling recommended  
 Ø2.5 mm (3/32")

Patent Pending



**Order Number**  
**LEFT .....25-932A**  
**RIGHT .....25-932B**

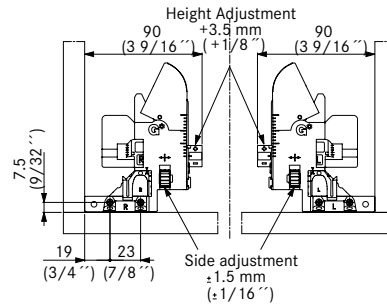

### Rear mounting socket for 12" - 21" slides

- For 12" - 21" drawers
- For Face Frame application
- Heavy duty slide must be blocked out for Face Frame application

Pre-drilling recommended  
 Ø2.5 mm (3/32")



**Order Number 25-948**

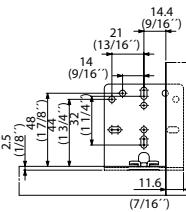

### Rear mounting socket for 9" slide

- For 9" drawer
- For Face Frame application
- For installation depth min. 269 mm (10 1/2") to 299 mm (11 3/4")

Pre-drilling recommended  
 Ø2.5 mm (3/32")

**Special Order**

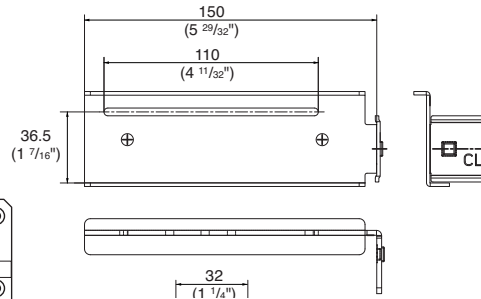
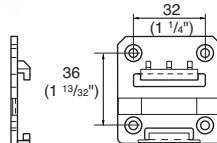

### Narrow front locking device

- For 1-dimensional and 2-dimensional drawers
- For narrow and standard width drawers
- For narrow and standard width inset drawers
- Minimum inside drawer width 95 mm (3 3/4")

Pre-drilling recommended  
 Ø2.5 mm (3/32")



**Order Number 25-932E.....Left**  
**Order Number 25-932F...Right**

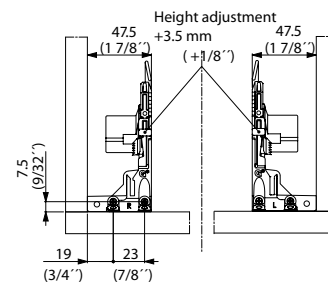

### Adjustment adapter

- Provides tilt adjustment with Dynapro 3-D and Dynapro 3-D heavy duty
- Tilt adjustment +4 mm (5/32")
- For Frameless or Face Frame application

Pre-drilling recommended  
 Ø2.5 mm (3/32")



**Order Number 25-932C.....Left**  
**Order Number 25-932D...Right**

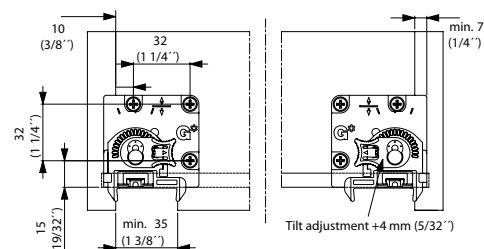

Kitchens

Doors

Kitchen Accessories

Hinges

Drawer Slides

Plywood Melamine

Veneer Edgebanding

Laminate

Solid Surface

Closets

Furniture Hardware

Pulls & Knobs

Lighting

Grommets

Locks, Lock Systems

Molding, Carvings

Tools

Adhesives Solvents Abrasives

Chemicals Staples Screws

## Zargen 6036 System



Kitchens

Doors

Kitchen Accessories

Hinges

Drawer Slides

Plywood Melamine

Veneer Edgebanding

Laminate

Solid Surface

Closets

Furniture Hardware

Pulls & Knobs

Lighting

Grommets

Locks, Lock Systems

Molding, Carvings

Tools

Adhesives Solvents Abrasives

Chemicals Staples Screws

### Description

- Integrated drawer slide and drawer side
- Self-closing feature with 60 mm (2 3/8") closing range
- Built-in drawer front bumpers
- Quick assembly through dowelled and integrated front fixing brackets
- White baked-on epoxy finish
- Tolerance adjustment 2 mm (3/32")
- LOAD capacity: 100 lbs.
- Adjustment: Height ( $\pm 2$  mm), Side ( $\pm 1.5$  mm)

85mm (3 3/8") Side Height



### ORDER NUMBERS

350 mm (14")	.....	<b>25-754</b>
400 mm (16")	.....	<b>25-756</b>
440 mm (18")	.....	<b>25-758</b>
470 mm (18 1/2")	.....	<b>25-760</b>
510 mm (20")	.....	<b>25-748</b>
550 mm (22")	.....	<b>25-762</b>

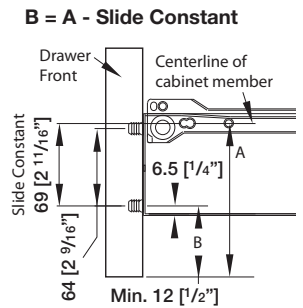
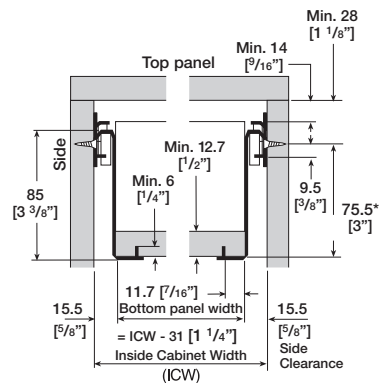
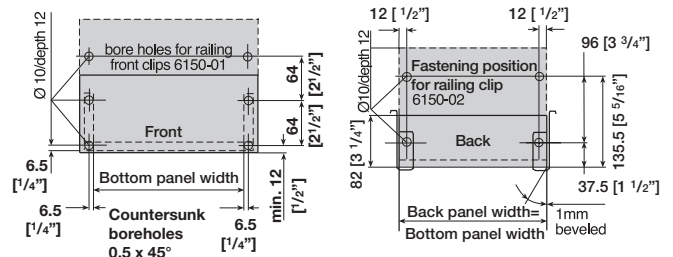
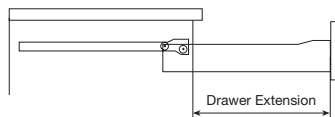
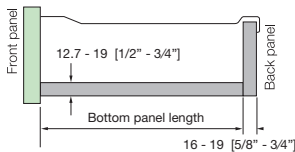
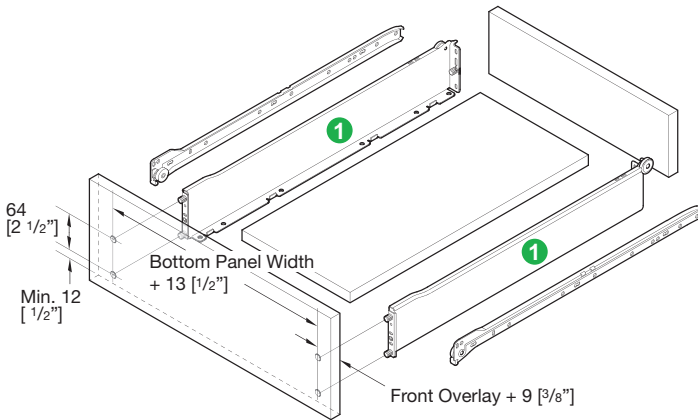

\*Allow minimum of 3mm [1/8"] for bottom clearance. If screws are used, increase clearance accordingly.

Dimensions in millimeters, approximate fractional inch equivalents as noted.

Subject to technical modifications without notice.

### Description

- Integrated drawer slide and drawer side
- Self-closing feature with 60 mm (2 3/8") closing range
- Built-in drawer front bumpers
- Quick assembly through dowelled and integrated front fixing brackets
- White baked-on epoxy finish
- Tolerance adjustment 2 mm (3/32")
- LOAD capacity: 100 lbs.
- Adjustment: Height ( $\pm 1.5$  mm), Side ( $\pm 1.2$  mm) - Manual adjustment by moving front to required position.

85mm (3 3/8") Side Height

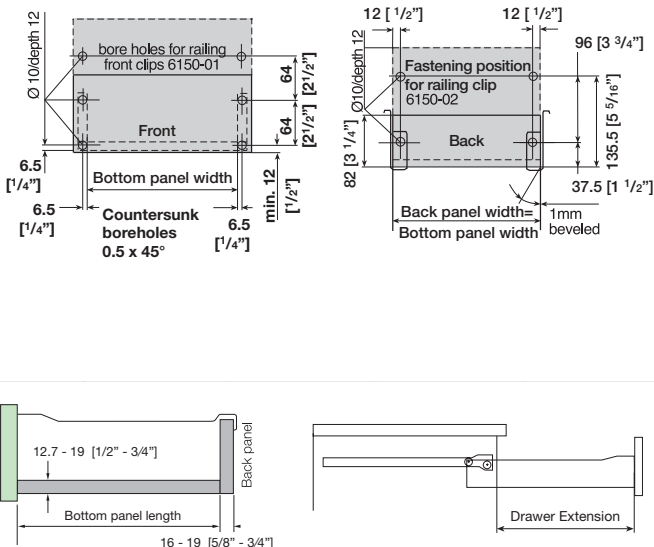

### ORDER NUMBERS

Pack 10 pcs.

350 mm (14")	.....25-861
400 mm (16")	.....25-863
470 mm (18 1/2")	.....25-866
510 mm (20")	.....25-751
550 mm (22")	.....25-868

BULK PACK 400 pcs.

470 mm (18")	.....25-954
510 mm (20")	.....25-747

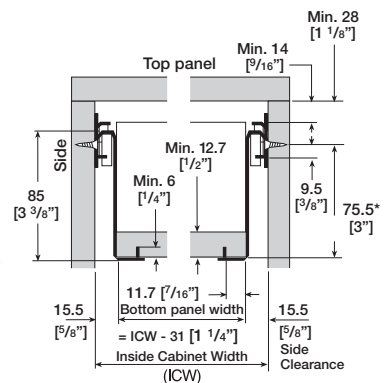
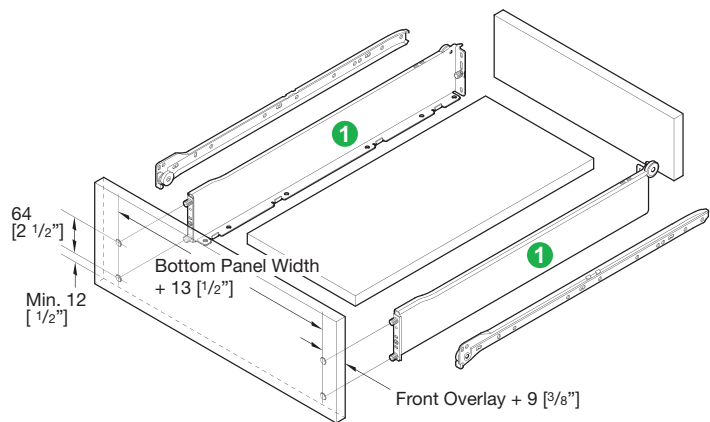

B = A - Slide Constant

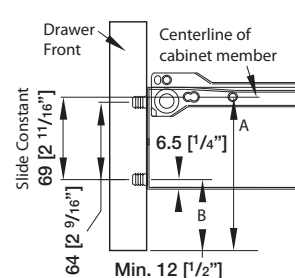

\*Allow minimum of 3mm [1/8"] for bottom clearance. If screws are used, increase clearance accordingly.

Dimensions in millimeters, approximate fractional inch equivalents as noted.

Subject to technical modifications without notice.

Kitchens

Doors

Kitchen Accessories

Hinges

Drawer Slides

Plywood Melamine

Veneer Edgebanding

Laminate

Solid Surface

Closets

Furniture Hardware

Pulls & Knobs

Lighting

Grommets

Locks, Lock Systems

Molding, Carvings

Tools

Adhesives Solvents Abrasives

Chemicals Staples Screws

## Zargen 6236 System



Kitchens

### Description

- Integrated drawer slide and drawer side
- Self-closing feature with 60 mm (2 3/8") Closing range
- Material thickness 1.3 mm (1/16")
- Built-in drawer front bumpers
- Quick assembly through dowelled and integrated front fixing brackets
- White baked-on epoxy finish
- Tolerance adjustment 2 mm (3/32")
- LOAD capacity: 100 lbs.
- Adjustment: Height ( $\pm 2$  mm), Side ( $\pm 1.5$  mm)

149mm (5 7/8") Side Height



### ORDER NUMBERS

350 mm (14")	.....	<b>25-787</b>
400 mm (16")	.....	<b>25-847</b>
440 mm (18")	.....	<b>25-848</b>
470 mm (18 1/2")	.....	<b>25-880</b>
510 mm (20")	.....	<b>25-780</b>
550 mm (22")	.....	<b>25-862</b>

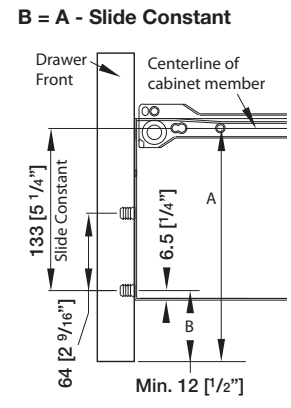
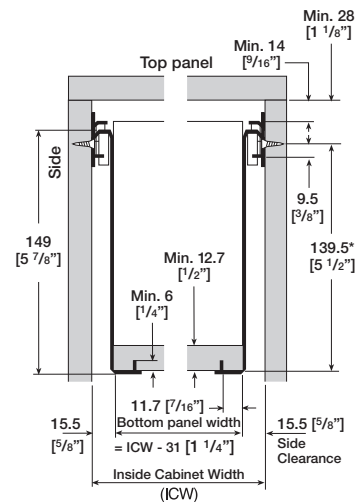
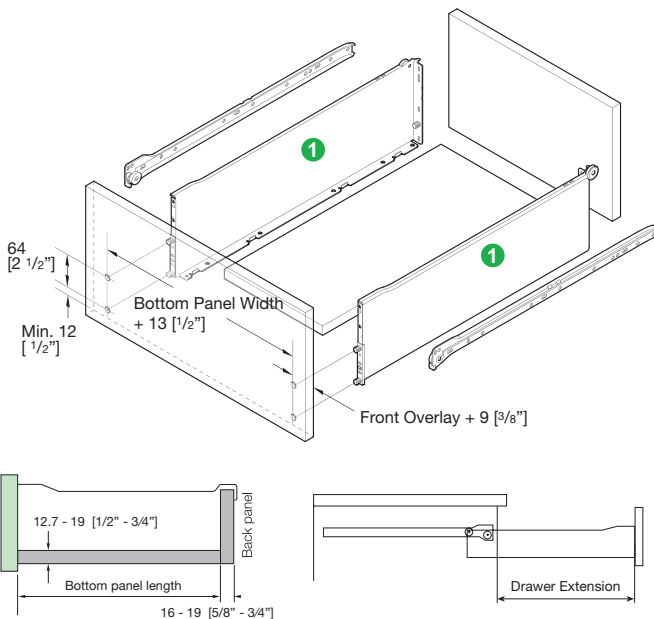
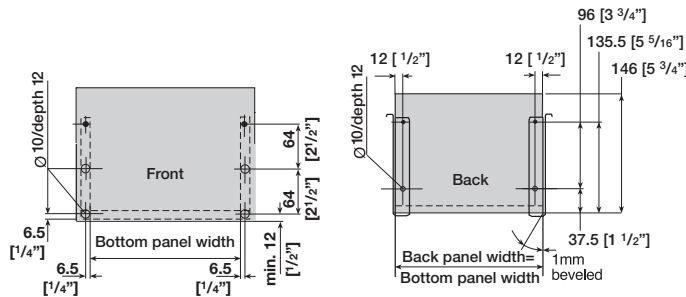

\*Allow minimum of 3mm [1/8"] for bottom clearance. If screws are used, increase clearance accordingly.

Subject to technical modifications without notice.

Dimensions in millimeters, approximate fractional inch equivalents as noted.

### Description

- Integrated drawer slide and drawer side
- Self-closing feature with 60 mm (2 3/8") Closing range
- Material thickness 1.3 mm (1/16")
- Built-in drawer front bumpers
- Quick assembly through dowelled and integrated front fixing brackets
- White baked-on epoxy finish
- Tolerance adjustment 2 mm (3/32")
- LOAD capacity: 100 lbs.
- Adjustment: Height ( $\pm 2$  mm), Side ( $\pm 1.5$  mm)

213mm (8 3/8") Side Height

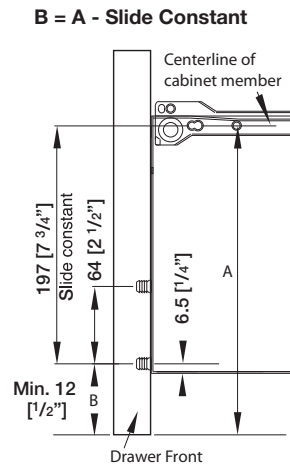
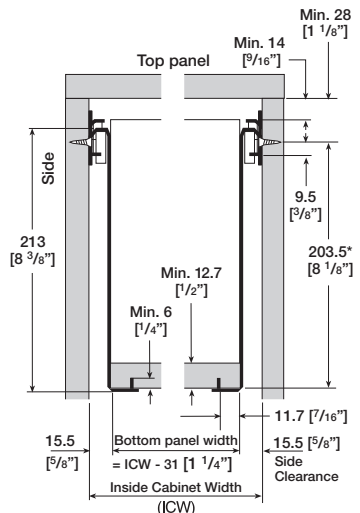
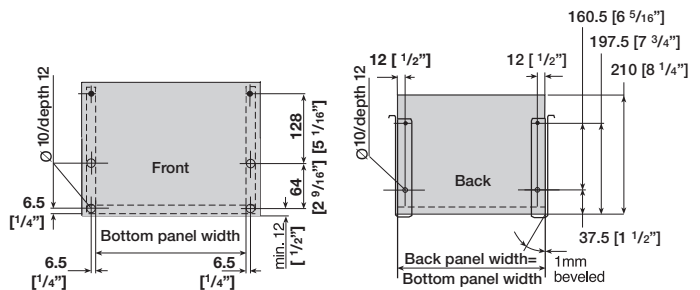
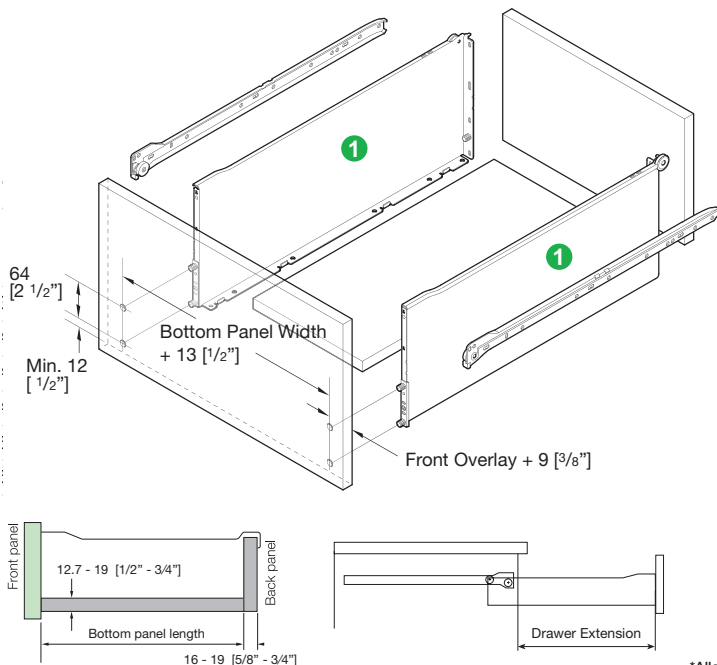

\*Allow minimum of 3mm [1/8"] for bottom clearance. If screws are used, increase clearance accordingly.

Dimensions in millimeters, approximate fractional inch equivalents as noted.

Kitchens

Doors

Kitchen Accessories

Hinges

Drawer Slides

Plywood Melamine

Veneer Edgebanding

Laminate

Solid Surface

Closets

Furniture Hardware

Pulls & Knobs

Lighting

Grommets

Locks, Lock Systems

Molding, Carvings

Tools

Adhesives Solvents Abrasives

Chemicals Staples Screws



## Zargen 6100 System



Kitchens

Doors

Kitchen Accessories

Hinges

Drawer Slides

Plywood Melamine

Veneer Edgebanding

Laminate

Solid Surface

Closets

Furniture Hardware

Pulls & Knobs

Lighting

Grommets

Locks, Lock Systems

Molding, Carvings

Tools

Adhesives Solvents Abrasives

Chemicals Staples Screws

### Description

- Designed for use with Systems 6034, 6035, 6036, 6026, 6136, and 6236
- Easy to construct
- Allows end user to customize storage space
- Includes convenient rail dividers
- Available in white

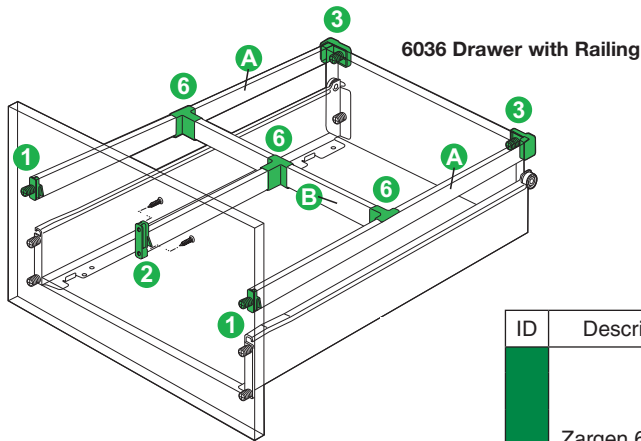

ID	Description	Length	Ref#	Order Number
A	Zargen 6100-02 Side Railing	270 (10 5/8")	6100-02 265 (10 7/16")	<b>25-712</b>
		350 (13 3/4")	6100-02 345 (13 9/16")	<b>25-698</b>
		400 (15 3/4")	6100-02 395 (15 9/16")	<b>25-714</b>
		510 (20 1/16")	6100-02 505 (20")	<b>25-720</b>
		550 (21 5/8")	6100-02 545 (21 3/8")	<b>25-722</b>
B	Zargen 6100-02 Divider Railing	*Railing length 1000 (39 3/8")	6100-02 1000 (39 3/8")	<b>25-726</b>

Front railing clip Dowelled

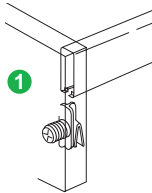

Front partition clip Screw-on

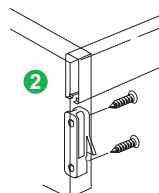

Back railing clip Dowelled

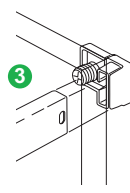

Back railing clip Screw-on

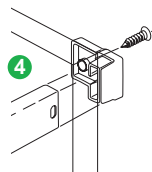

Back partition clip Screw-on

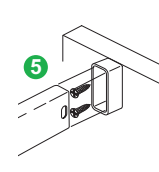

Divider railing clip

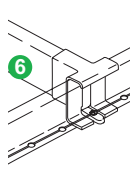

Stacking corner bracket

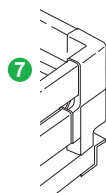

Corner bracket

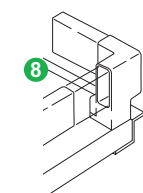

### Pendaflex - File Railing System

ID	Description	Ref#	Order Number
1	Side Rails 470	01692-05	<b>25-852</b>
1	Side Rails 510		<b>25-854</b>
1	Side Rails 550		<b>25-856</b>
2	File Bar		<b>25-858</b>
3	Lateral File Clip		<b>25-860</b>

ID	Description	Ref#	Order Number
1	Front railing clip, dowelled	6150/01	<b>25-728</b>
2	Front partition clip, screw-on	6150/HF 4.2	<b>25-810</b>
3	Back railing clip, dowelled	6150/02	<b>25-746</b>
4	Back railing clip, screw-on	6150/03	<b>25-730</b>
5	Back partition clip, screw-on	6150-20/4.2	<b>25-812</b>
6	Divider railing clip	6180/01	<b>25-732</b>
7	Stacking corner bracket	6190/HDD	<b>25-738</b>
8a	Corner bracket, left hand	6190/01	<b>25-734</b>
8b	Corner bracket, right hand	6190/02	<b>25-736</b>



## Zargen 6200 System

### Description

- Integrated drawer slide and drawer side
- Self-closing feature with 60 mm (2 3/8") closing range
- Built-in drawer front bumpers
- Quick assembly through dowelled and integrated front fixing brackets
- White baked-on epoxy finish
- Tolerance adjustment 2 mm (3/32")
- LOAD capacity: 100 lbs.
- Adjustment: Height ( $\pm 2$  mm), Side ( $\pm 1.5$  mm)

### ORDER NUMBERS

- 270 mm (10").....**25-764**
- 350 mm (14").....**25-766**
- 400 mm (16").....**25-768**
- 510 mm (20").....**25-774**
- 550 mm (22").....**25-776**



System 6035

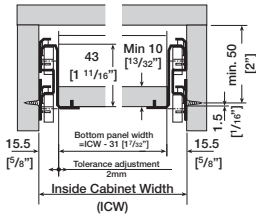

System 6036/6026

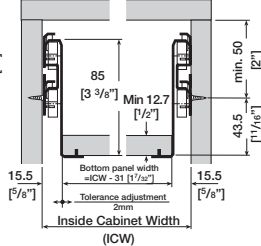

System 6136

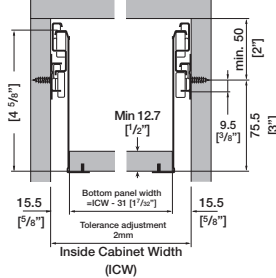

System 6236

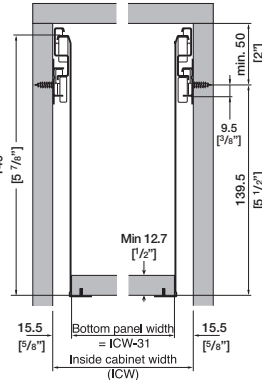

System 6436

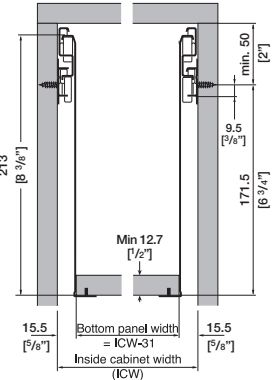

Slide Length	Drawer Extension	
	Single Stop	Double Stop
270 (10 5/8")	200 (7 7/8")	-
350 (13 3/4")	280 (11")	-
400 (15 3/4")	300 (11 13/16")	314 (12 3/8")
440 (17 3/8")	340 (13 3/8")	354 (13 15/16")
470 (18 1/2")	370 (14 9/16")	384 (15 1/8")
510 (20 1/16")	410 (16 1/8")	424 (16 11/16")
550 (21 5/8")	450 (17 11/16")	464 (18 1/4")

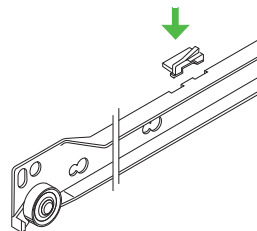

### 6200 Member Installation

1. Attach clip to left cabinet member to prevent full extension member from slipping.
2. Mount cabinet member of the drawer slide (System 6035, 6026, 6036, 6136, 6236 or 6436) according to installation measurements.
3. Install full extension slide member by simple insertion.
4. Insert drawer, pull-out or shelf.

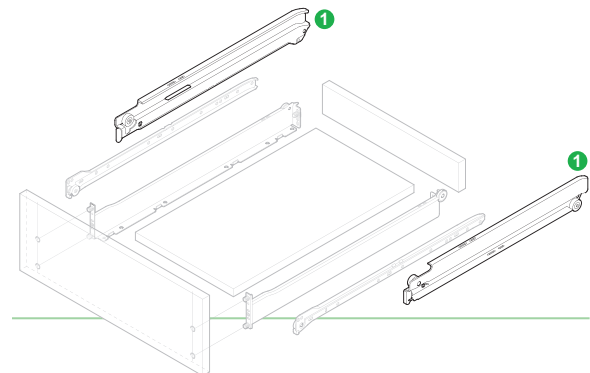

Kitchens

Doors

Kitchen Accessories

Hinges

Drawer Slides

Plywood Melamine

Veneer Edgbanding

Laminate

Solid Surface

Closets

Furniture Hardware

Pulls & Knobs

Lighting

Grommets

Locks, Lock Systems

Molding, Carvings

Tools

Adhesives Solvents Abrasives

Chemicals Staples Screws

## Integra Quick Pencil Drawer

Kitchens

### Description

- Doors
  - Metal drawer system
  - Color: white
- Kitchen Accessories
  - Single extension, height 53 mm (2-1/16")
  - LOAD capacity 100 lbs.
- Hinges
  - Installation width 15.5 mm (5/8")
  - Screw-on bottom

Drawer Slides



Plywood Melamine

### ORDER NUMBERS

Veneer	350 mm (14")	.....26-319
Edgebanding	400 mm (16")	.....26-321
	450 mm (18")	.....26-323
Laminate	500 mm (20")	.....26-325
	550 mm (22")	.....26-327

Solid Surface

Closets

Furniture Hardware

Pulls & Knobs

Lighting

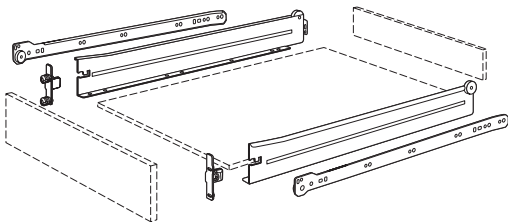

Grommets

Locks, Lock Systems

Molding, Carvings

Tools

Adhesives Solvents Abrasives

Chemicals Staples Screws

### Metal drawer system, height 53 mm (2-1/16")

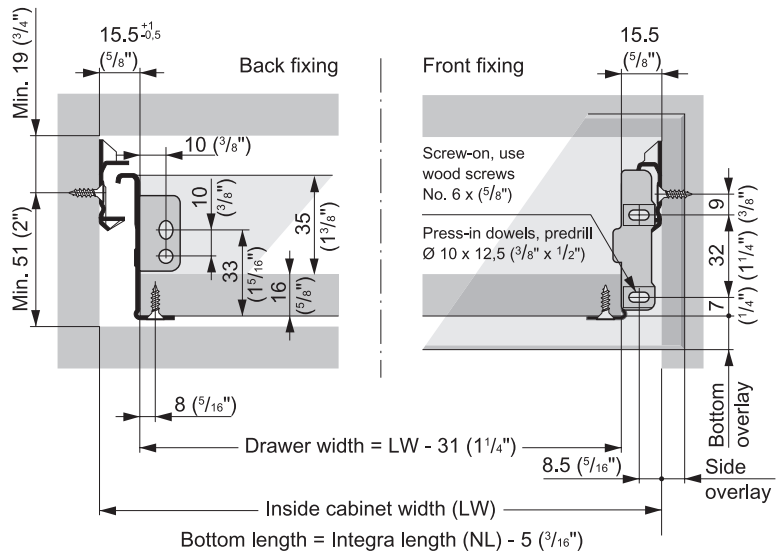

### Front Fixing Bracket ORDER NUMBERS

Screw-on	..... left 26-311	..... right 26-313
Press-in dowels	..... left 26-351	..... right 26-353

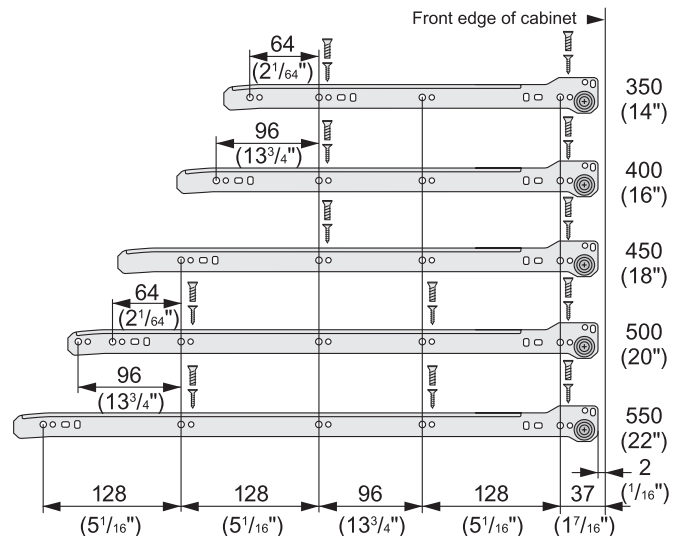

## Metal drawer system, height 85 mm (3-3/8")

# Integra Quick



### Description

- Metal drawer system
- Color: white
- Single extension, height 85 mm (3-3/8")
- LOAD capacity 100 lbs.
- Installation width 15.5 mm (5/8")
- Snap-in bottom

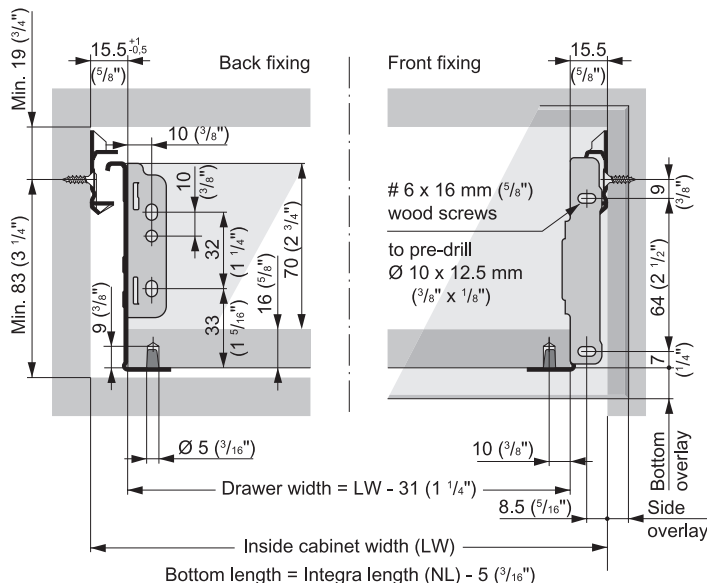
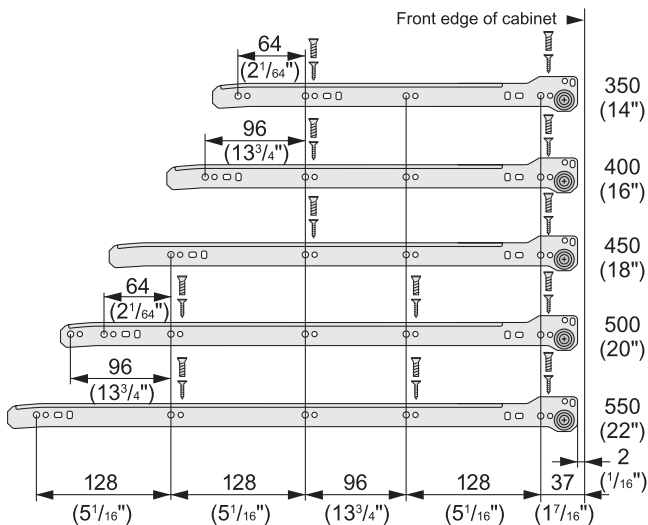

### ORDER NUMBERS

350 mm (14")	.....	<b>26-431</b>
400 mm (16")	.....	<b>26-433</b>
450 mm (18")	.....	<b>26-435</b>
500 mm (20")	.....	<b>26-437</b>
550 mm (22")	.....	<b>26-439</b>

### Cover Caps

20 pieces	.....	<b>26-399</b>
-----------	-------	---------------

### Front Fixing Click-on

#### ORDER NUMBERS

Screw-on	..... left	<b>26-405</b>	..... right	<b>26-407</b>
Press-in dowels	..... left	<b>26-401</b>	..... right	<b>26-403</b>

### Front Fixing Slide-on

#### ORDER NUMBERS

Screw-on	..... left	<b>26-413</b>	..... right	<b>26-415</b>
Press-in dowels	..... left	<b>26-357</b>	..... right	<b>26-359</b>

## Integra Quick with screw-less assembly

**FOR EASY AND  
TIMESAVING  
BOTTOM  
MOUNTING**

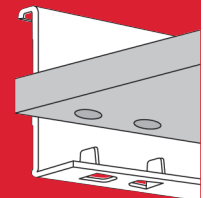

**G\* GRASS**

Kitchens

Doors

Kitchen  
Accessories

Hinges

Drawer  
Slides

Plywood  
Melamine

Veneer  
Edgebanding

Laminate

Solid  
Surface

Closets

Furniture  
Hardware

Pulls  
&  
Knobs

Lighting

Grommets

Locks,  
Lock  
Systems

Molding,  
Carvings

Tools

Adhesives  
Solvents  
Abrasives

Chemicals  
Staples  
Screws

## Integra Quick 9313

Metal drawer system, height 149 mm (5-3/8")

### Description



- Metal drawer system
- Color: white
- Single extension, height 149 mm (5-3/8")
- LOAD capacity 100 lbs.
- Installation width 15.5 mm (5/8")
- Snap-in bottom mounting



Kitchens

Doors

Kitchen Accessories

Hinges

Drawer Slides

### ORDER NUMBERS

Plywood	350 mm (14").....	26-455
Melamine	400 mm (16").....	26-457
	450 mm (18").....	26-459
Veneer	500 mm (20").....	26-461
Edgebanding	550 mm (22").....	26-463



Integra Quick with screw-less assembly

FOR EASY AND  
TIMESAVING  
BOTTOM  
MOUNTING



Laminate

Solid Surface

## Integra Full Extension

Full extension components for sides with height 53 mm, 85 mm, 117 mm, and 149 mm



### Description

- Full extension components for sides with height 53 (2-1/16"), 85 (3-3/8"), 117 (4-5/8"), and 149 (5-7/8")
- Color: white
- LOAD capacity 100 lbs.
- Installation width 15.5 mm (5/8")

### ORDER NUMBERS

350 mm (14").....	26-471
400 mm (16").....	26-473
450 mm (18").....	26-475
500 mm (20").....	26-477
550 mm (22").....	26-479

Closets

Furniture Hardware

Pulls & Knobs

Lighting

Grommets

Locks, Lock Systems

Molding, Carvings

Tools

Adhesives Solvents Abrasives

Chemicals Staples Screws

## Integra Interior Drawer

Front fixing adapters for heights 85 mm (3-3/8") and 149 mm (5-7/8")

### Description

- Front fixing adapters for interior drawers
- Color: white
- Screw-on

ORDER NUMBERS  
for 85 mm height .....26-139  
for 149 mm height ....26-453

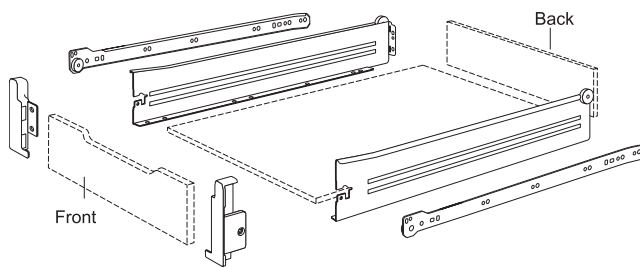



## Adjustable Gallery Rail System

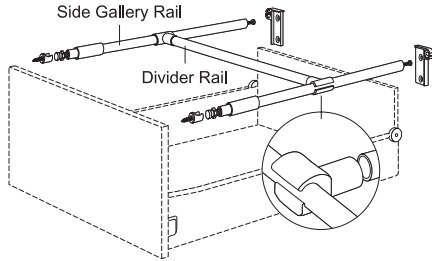

For screw-on front fixing

### Consists of:

- 2 Side Gallery Rails
- 2 Front fixing parts
- 2 Back fixing parts

- 2 Cover caps

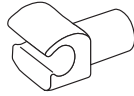

Divider clip ..... **26-165**  
 500 mm (20") ..... **26-171**  
 550 mm (22") ..... **26-173**



### ORDER NUMBERS (Drawer Length)

Kitchens  
Doors  
Kitchen Accessories  
Hinges

## File Railing

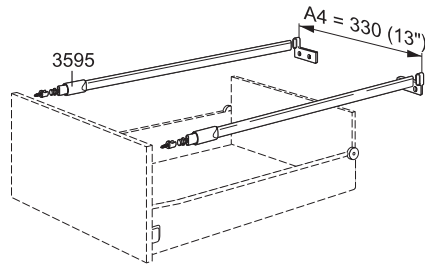

### Consists of:

- 2 Side Gallery Rails
- 2 Front fixing parts
- 2 Back fixing parts
- 2 Cover caps

## Integra File



### ORDER NUMBERS (Drawer Length)

500 mm (20") ..... **26-175**  
 550 mm (22") ..... **26-177**

Drawer Slides  
Plywood Melamine  
Veneer Edgebanding  
Laminate  
Solid Surface  
Closets

## Predrilling of fixings positions for Integra front fixing and Integra Quick bottom mounting



Drilling jig ..... **26-219**

### Including:

- Jig
- Marker Ø 5 mm (3/16")
- Marker Ø 10 mm (3/8")



## Integra Drilling Jig

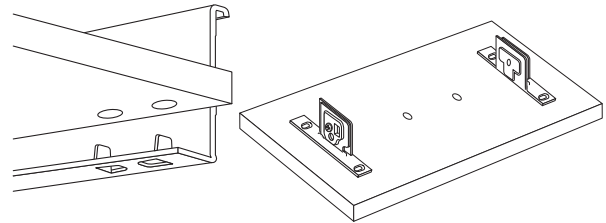

Furniture Hardware  
Pulls & Knobs  
Lighting  
Grommets  
Locks, Lock Systems

## For Front Fixing 9105 / 9205 / 9305

### Including:

- Left part
- Right part
- 4 Marker tips

Order number ..... **26-217**

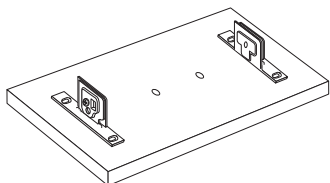

## Integra Marker Jigs

### For Front Fixing 9005

### Including:

- Left part
- Right part
- 4 Marker tips

Order number ..... **26-215**



Molding, Carvings  
Tools  
Adhesives Solvents  
Abrasives  
Chemicals  
Staples  
Screws

# SLIDES

## 1702 Drawer Slide



### Description

- White under-mount
- Self & Parallel-closing
- 100 lb. Capacity
- Double stop
- Packed 25 pair with screws

### ORDER NUMBERS

12".....	<b>26-302</b>	20".....	<b>26-310</b>
14".....	<b>26-304</b>	22".....	<b>26-312</b>
16".....	<b>26-306</b>		
18".....	<b>26-308</b>		

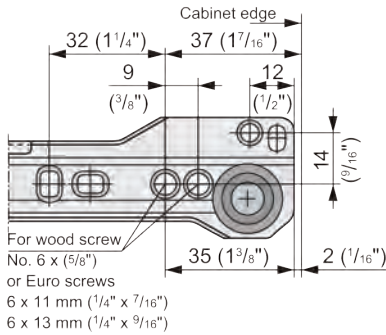
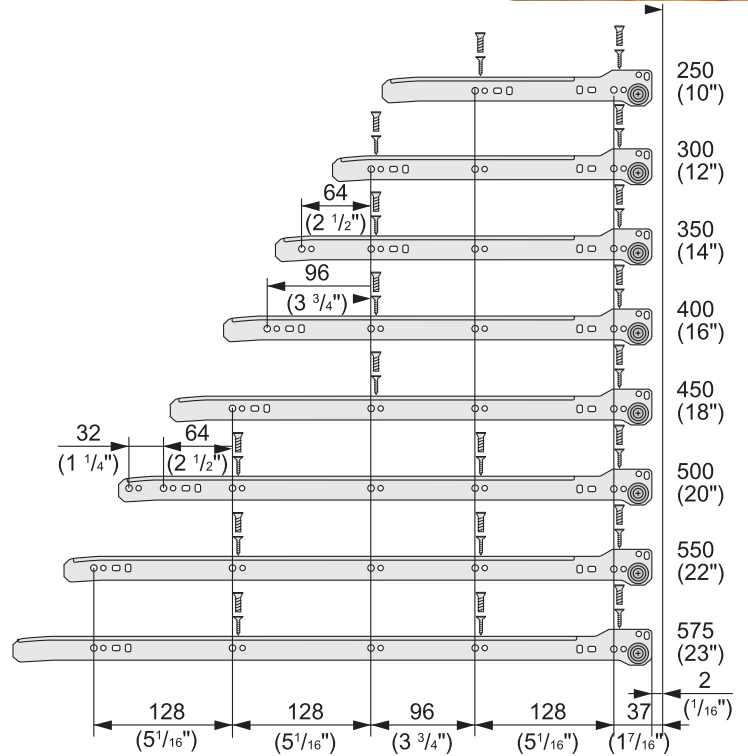
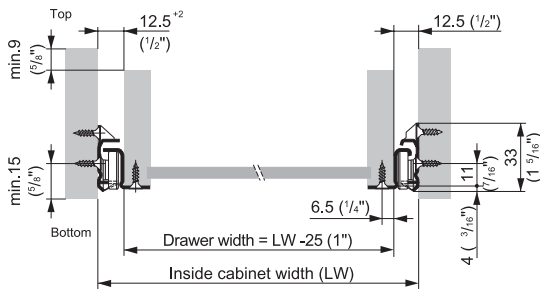

## Rear Mount Bracket for 1702



### ORDER NUMBERS

Screw-mount.....left **26-290**..... right **26-292**  
(ABS copolymer)

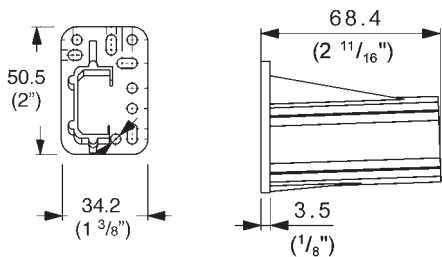

Most of the merchandise in this catalog is available in all Hardware Imagination-Tech locations. If your selection isn't available at the store nearest you, we'll gladly order it from one of the other stores or through special order.

# SLIDES

To provide side clearance for interior drawers and Pull-out shelves.

## Symmetrical Distance Block

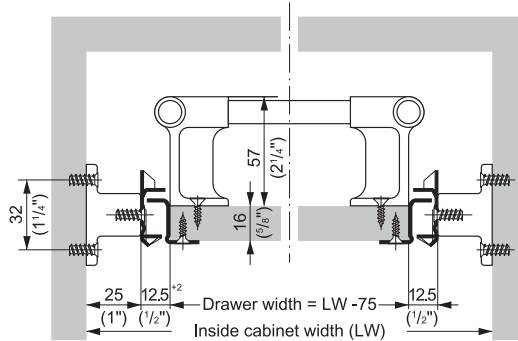

Plastic, white.....25-312

To provide side clearance for interior drawers and Pull-out shelves.

## Asymmetrical Distance Block

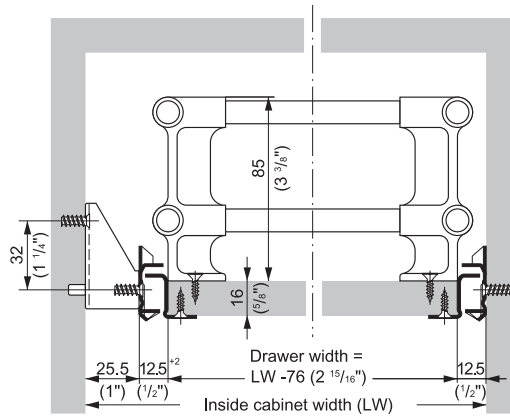

Plastic, white.....25-340

4" Rear Mount Socket for Integra  
For single extension slide

## Rear Mount Socket

ORDER NUMBERS

Left..... 26-296 Right..... 26-298

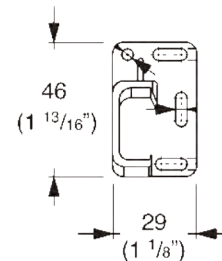
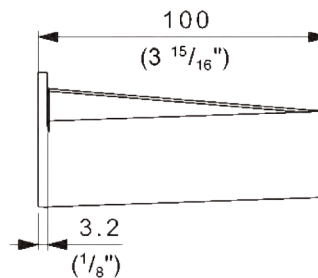

Kitchens

Doors

Kitchen Accessories

Hinges

Drawer Slides

Plywood Melamine

Veneer Edgebanding

Laminate

Solid Surface

Closets

Furniture Hardware

Pulls & Knobs

Lighting

Grommets

Locks, Lock Systems

Molding, Carvings

Tools

Adhesives Solvents Abrasives

Chemicals Staples Screws



## DWD-Dynamic-XP Drawer Set

Kitchens

Doors

Kitchen Accessories

Hinges

Drawer Slides

Plywood Melamine

Veneer Edgebanding

Laminate

Solid Surface

Closets

Furniture Hardware

Pulls & Knobs

Lighting

Grommets

Locks, Lock Systems

Molding, Carvings

Tools

Adhesives Solvents Abrasives

Chemicals Staples Screws

### 1 Set consists of

- DWD XP drawer sides height 95 mm (3-3/4"), left and right with cover caps
- Dynamic XP full extension slides 100 lbs. or 135 lbs. depending on drawer size
- Screw-on front fixings (for both left & right)
- self-close / soft-close
- Adapters for wooden drawer back

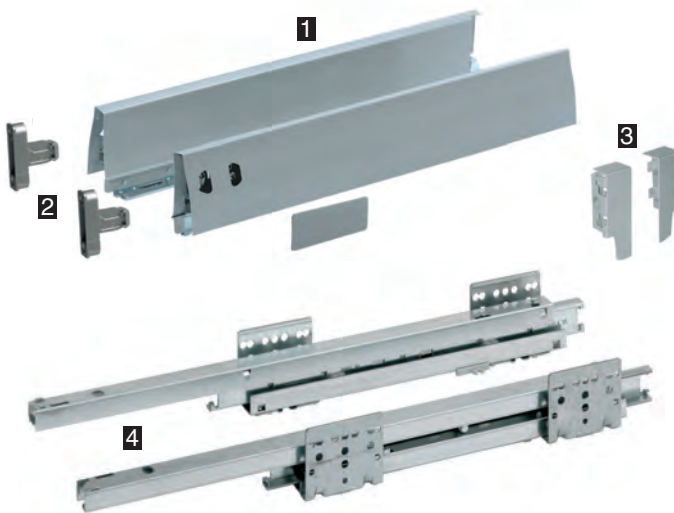

- 1** Double wall steel drawer sides, left and right with cover caps
- 2** Screw-on front fixing brackets
- 3** Adapter set for wooden drawer back height 86 mm (3-3/8")
- 4** Dynamic XP full extension slides

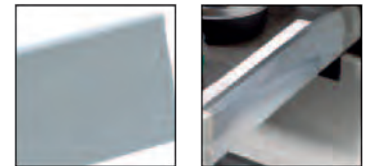

### Benefits

- Optional logistics and storing
- Easy, convenient ordering and storage
- User-friendly front adjustment
- Quick and easy assembly

### Features

- Identical drawer profile for various LOAD ratings and add-on system
- Set packaging
- 2-dimensional front adjustment
- Knock-in or screw-on bottom mounting

### ORDER NUMBERS

	Alumetallic	Stainless Steel
350 mm (13-3/4"), Cap. 110 lbs. ....	25-508	25-004
400 mm (15-3/4"), Cap. 110 lbs. ....	25-510	25-006
450 mm (17-11/16"), Cap. 110 lbs. ....	25-512	25-008
500 mm (19-11/16"), Cap. 110 lbs. ....	25-514	25-010
550 mm (21-5/8"), Cap. 110 lbs. ....	25-516	25-012



### Front Fixing Bracket:

- with dowels ..... 25-502
- with expandable dowels ..... 25-504

## Inset drawer front profile with front fixings

## DWD XP Inset Drawer

### Description

- Aluminum front profile and ABS front fixings

### Consisting of

- Front profile for inset drawer (cut to size)
- Front fixings left/right with screws

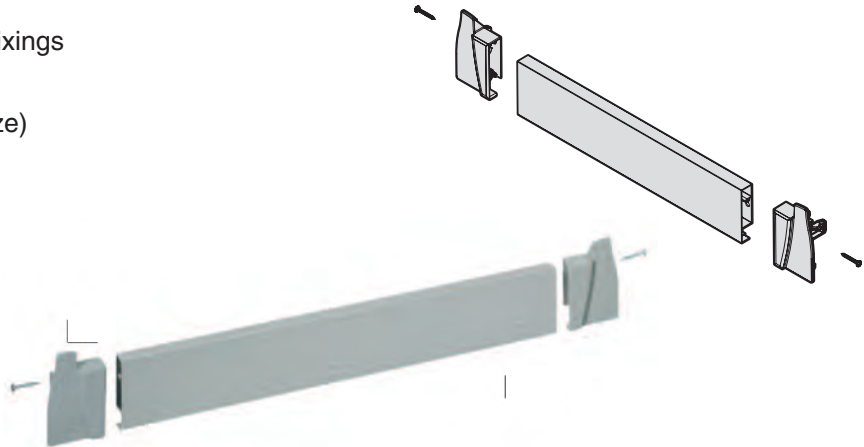

### ORDER NUMBERS

- Front profile for cabinet width 1200 (47-1/4")..... **25-906**  
 Front fixing, color: light-grey ..... **25-908**

Soft-close, 135 lbs.

## Dynamic XP Full Extension Slide

### Description

- Concealed, ball bearing full extension slide for DWD XP

### Consisting of

- Dynamix XP 175 lbs. full extension slides, left and right

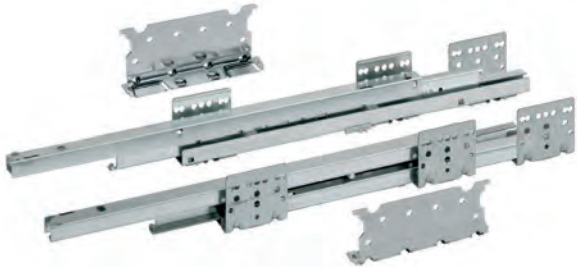

### Full Extension Slide ORDER NUMBERS

- 550 mm (21-5/8")..... **25-530**  
 600 mm (23-5/8") ..... **25-534**



## Front Drilling Jig

**Description:** Front drilling jig for DWD-XP front fixing, railings and add-on systems

**Features:** Drilling tool for drawer front

**Benefits:** Easy and precise positioning of front fixing

Order Number ..... **25-998**



## DWD XP Mounting Aids

### Marker Jig

**Description:** Set of marker jigs for DWD-XP front fixing

**Features:** Marker tool for drawer front

**Benefits:** Easy and precise positioning of screw-on front fixing

Order Number ..... **25-994**

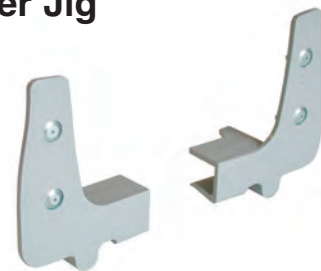

Kitchens

Doors

Kitchen Accessories

Hinges

Drawer Slides

Plywood Melamine

Veneer Edgebanding

Laminate

Solid Surface

Closets

Furniture Hardware

Pulls & Knobs

Lighting

Grommets

Locks, Lock Systems

Molding, Carvings

Tools

Adhesives Solvents Abrasives

Chemicals Staples Screws

## Pot & Pan Drawer Set

Kitchens

### 1 Set consists of

Doors

- DWD XP drawer sides height 95 mm (3-3/4"), left and right with cover caps

Kitchen Accessories

- Dynamic XP full extension slides 100 lbs.
- Screw-on front fixings (for both left & right)

Hinges

- Self-close / soft-close
- Pot drawer adapter set for wooden drawer back

Drawer Slides

- Adapters for wooden drawer back
- Magic Twin brackets screw-on version (for both left and right)
- Magix Twin profiles

Plywood Melamine

Veneer Edgebanding

Laminate

Solid Surface

Closets

Furniture Hardware

Pulls & Knobs

Lighting

Grommets

Locks, Lock Systems

Molding, Carvings

Tools

Adhesives Solvents Abrasives

Chemicals Staples Screws

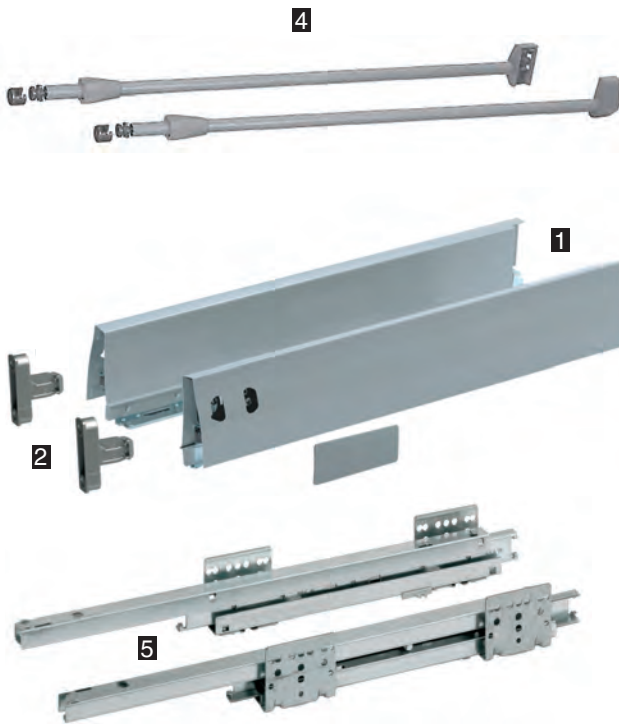
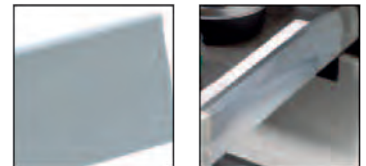

### ORDER NUMBERS

Alumetallic    Stainless Steel

350 mm (13-3/4"), Cap. 110 lbs. ....	25-505	25-520
400 mm (15-3/4"), Cap. 110 lbs. ....	25-507	25-521
450 mm (17-11/16"), Cap. 110 lbs. ....	25-509	25-523
500 mm (19-11/16"), Cap. 110 lbs. ....	25-511	25-515
550 mm (21-5/8"), Cap. 110 lbs. ....	25-517	25-525

- 1** Double wall steel drawer sides, left and right with cover caps
- 2** Screw-on front fixing brackets
- 3** Adapter set for wooden drawer back height 182 mm (7-3/16")
- 4** Magix Twin add-on profile set, left and right
- 5** Dynamic XP full extension slides 100 lbs.

## Inset Drawer

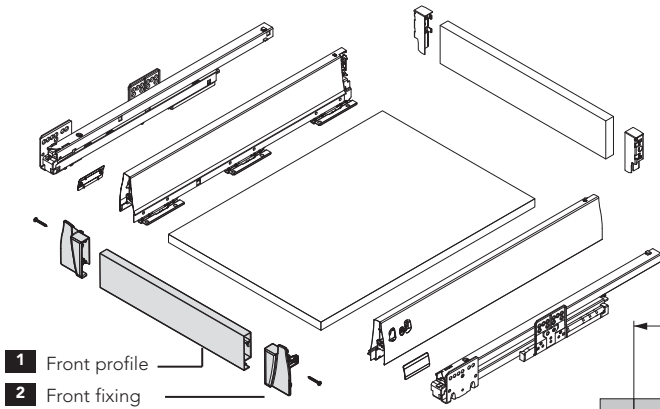

- 1 Front profile
- 2 Front fixing

## Cutting Dimensions on 16mm Particle Board

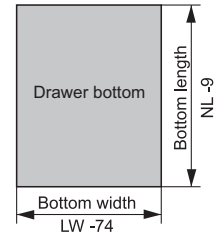
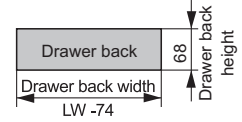

Minimum installation depth = NL  
 NL = Nominal length of slide  
 LW = Inside cabinet width

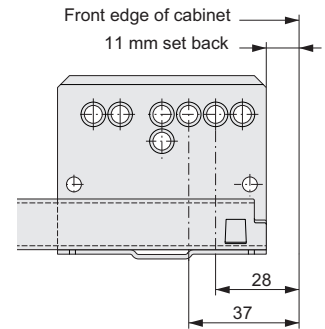

## Cutting Dimensions for Front Profile

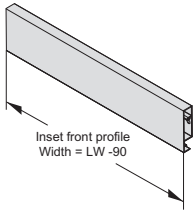

LW = Inside cabinet width

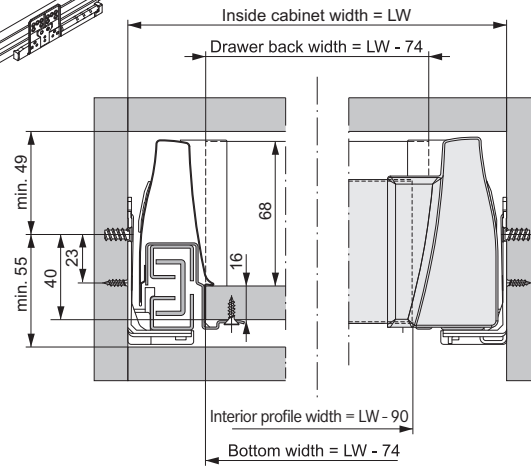

## Inset Drawer with Railing

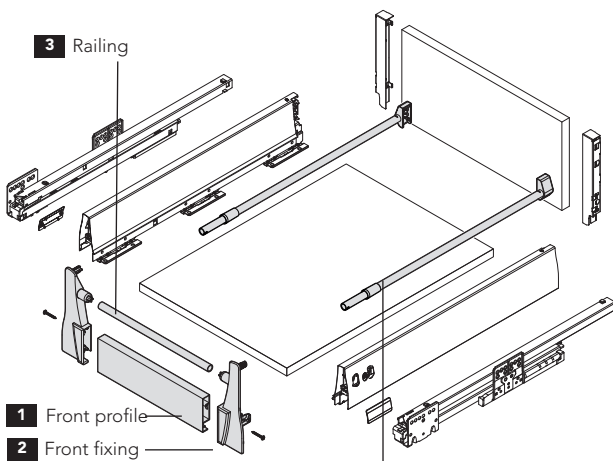

- 1 Front profile
- 2 Front fixing
- 3 Railing

## Cutting Dimensions on 16mm Particle Board

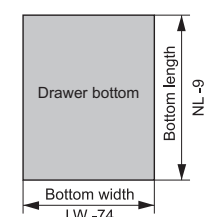
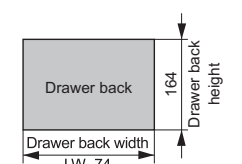

Minimum installation depth = NL  
 NL = Nominal length of slide  
 LW = Inside cabinet width

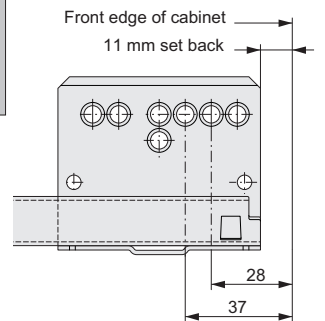

## Cutting Dimensions for Front Profile

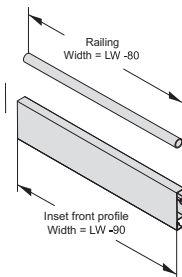

LW = Inside cabinet width

Side Railing for inset drawer: suitable for Solowing and Duowing

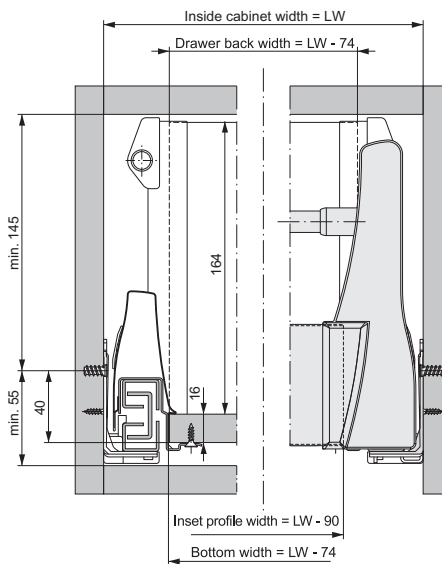

Kitchens

Doors

Kitchen Accessories

Hinges

Drawer Slides

Plywood Melamine

Veneer Edgebanding

Laminate

Solid Surface

Closets

Furniture Hardware

Pulls & Knobs

Lighting

Grommets

Locks, Lock Systems

Molding, Carvings

Tools

Adhesives Solvents Abrasives

Chemicals Staples Screws

## Magic Twin & Classic Organizing System

Kitchens

### Side Wing

Steel profiles for additional storage in the drawer

Doors

### Magic Twin and Classic Dividing Set –

Side and Divider Rails for Magic Twin and Magic Classic (to be cut to size)

Kitchen Accessories

Hinges

### ORDER NUMBERS

#### Side Wing

400 mm (15-3/4")..... **25-590**

450 mm (17-11/16")..... **25-592**

500 mm (19-11/16")..... **25-594**

550 mm (21-5/8")..... **25-596**

Drawer Slides

Plywood Melamine

Veneer Edgebanding

Laminate

Solid Surface

Closets

Furniture Hardware

Pulls & Knobs

Lighting

Grommets

Locks, Lock Systems

Molding, Carvings

Tools

Adhesives Solvents Abrasives

Chemicals Staples Screws

### Side Wing, Dividing Set

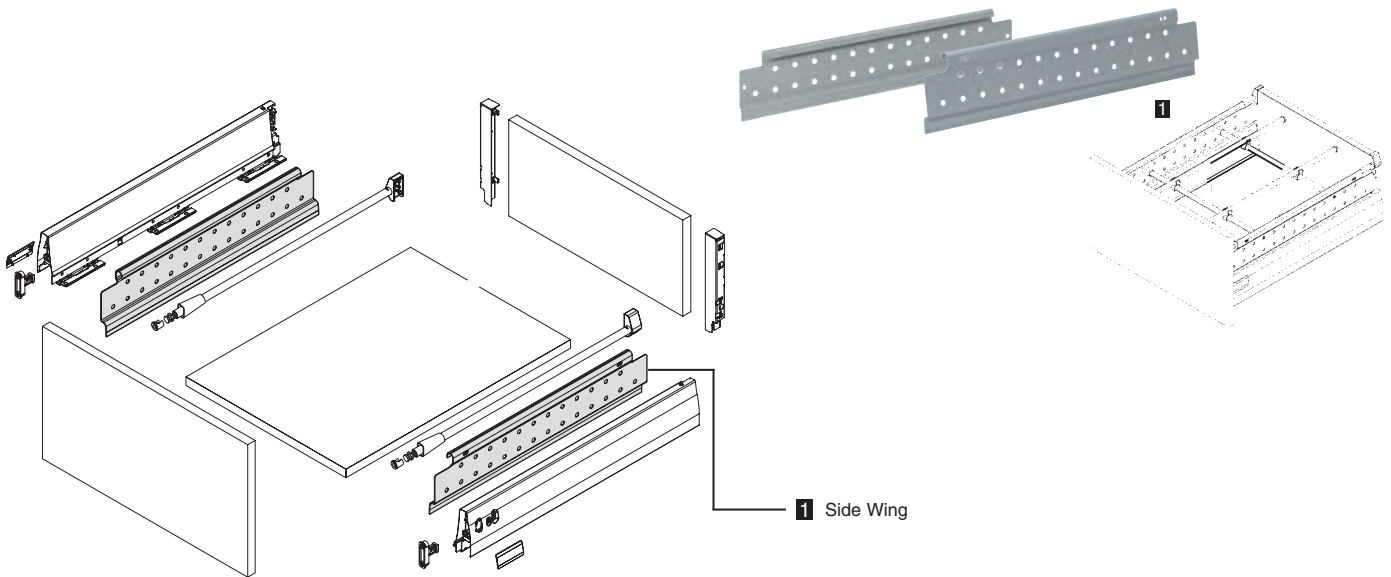

## Magic Sorto



Consisting of:

- 1 Sorto trays 450 x 90 mm
- 3 Sorto trays 270 x 90 mm
- 3 Sorto trays 180 x 90 mm
- 2 Spacer 180 mm
- 1 Divider Support

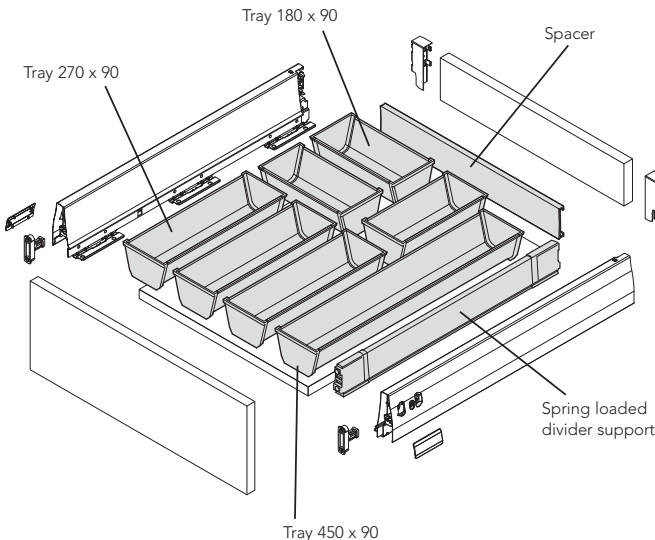
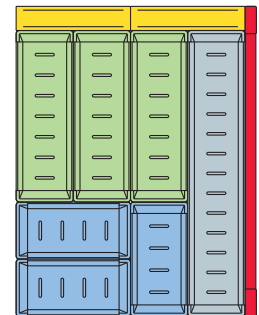

Magic Tray Set: Size: 520 mm Tray Set  
Order Number.....**25-900**

# SLIDES

## Description

- Extended Self-closing
- High quality epoxy coating
- Extra 32 mm installation holes
- 75 lb. capacity

## Samet Econo Slides

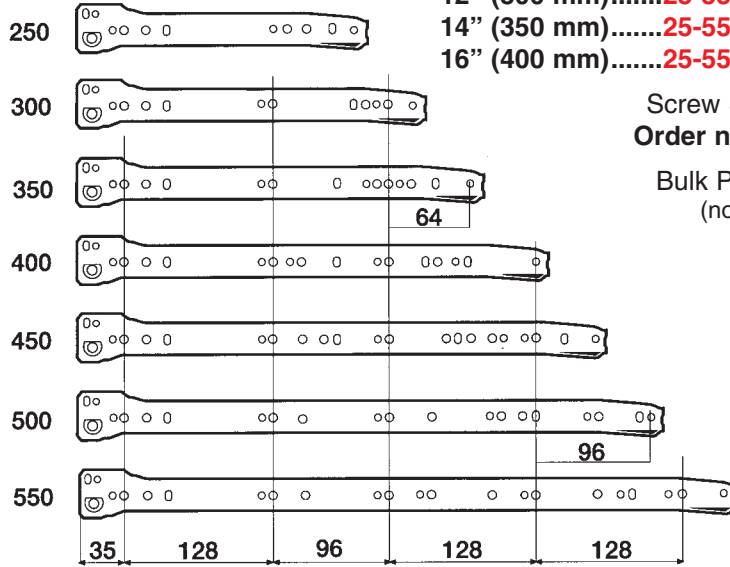

### ORDER NUMBERS

12" (300 mm).....	25-552	18" (450 mm).....	25-558
14" (350 mm).....	25-554	20" (500 mm).....	25-560
16" (400 mm).....	25-556	22" (550 mm).....	25-562

Screw Size 6 x 1/2"  
Order no. .... 19-664

Bulk Pack 25 Pair  
(no screws)



### MOUNTING FEATURES

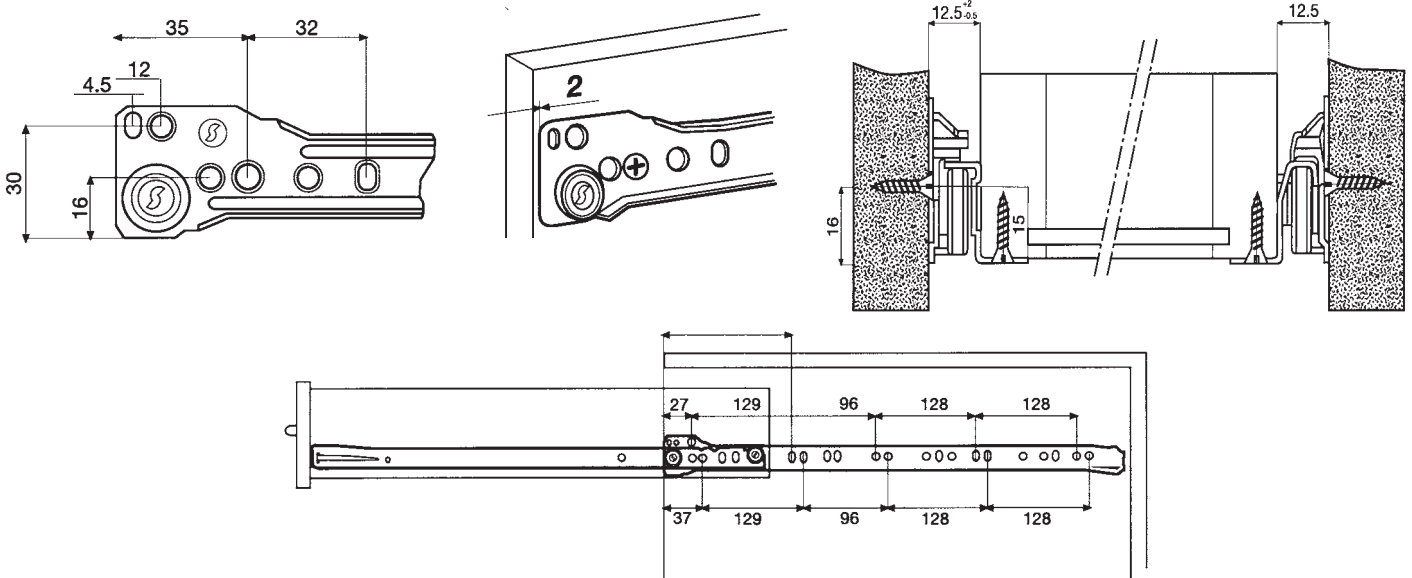

## Rear Mount Bracket for Samet

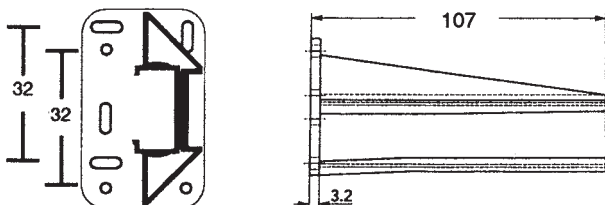

Order number (pair) ..... 26-914

Kitchens

Doors

Kitchen  
Accessories

Hinges

Drawer  
Slides

Plywood  
Melamine

Veneer  
Edgebanding

Laminate

Solid  
Surface

Closets

Furniture  
Hardware

Pulls  
&  
Knobs

Lighting

Grommets

Locks,  
Lock  
Systems

Molding,  
Carvings

Tools

Adhesives  
Solvents  
Abrasives

Chemicals  
Staples  
Screws

# SLIDES

## Stainless Steel Double Wall Undermount Soft-Close

- Concealed, Full Extension
- Dynamic LOAD Capacity: 40kg
- Finish: Stainless Steel
- Tool Free Assembly And Removal Of Drawer
- Silent System Guarantees Smooth Run Without Noise
- Up & Down Adjustment, Left & Right Adjustment



ORDER NUMBER	DESCRIPTION
25-505D-SS	14" DOUBLE-WALL FULL EXTENSION SLIDE
25-507D-SS	16" DOUBLE-WALL FULL EXTENSION SLIDE
25-509D-SS	18" DOUBLE-WALL FULL EXTENSION SLIDE
25-511D-SS	20" DOUBLE-WALL FULL EXTENSION SLIDE
25-516D-SS	22" DOUBLE-WALL FULL EXTENSION SLIDE

### KIT INCLUDES:

- #1 - SLIDES LEFT / RIGHT
- #2 - DRAWER SIDES
- #3 - BACK FIXING BRACKETS LEFT / RIGHT
- #4 - FRONT FIXING BRACKET LEFT / RIGHT
- #5 - COVER CAPS LEFT / RIGHT

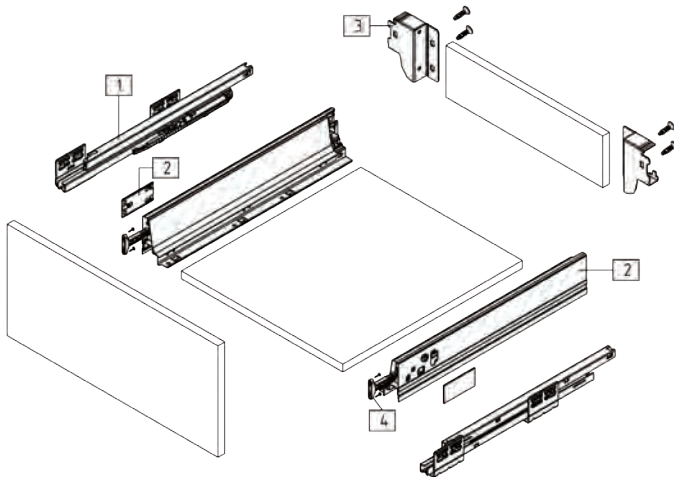





# SLIDES

## Stainless Steel Double Wall Undermount Soft-Close

- Concealed, Full Extension
- Dynamic LOAD Capacity: 40kg
- Finish: Stainless Steel
- Tool Free Assembly And Removal Of Drawer
- Silent System Guarantees Smooth Run Without Noise
- Up & Down Adjustment, Left & Right Adjustment



Note: Rails & Rear Brackets Are Chrome Plated.  
Picture Shows Rails For Visual Representation Only  
Picture Shows Front Brackets For Visual Representation Only

ORDER NUMBER	DESCRIPTION
25-505DR-SS	14" DOUBLE-WALL FULL EXTENSION SLIDE WITH SINGLE RAILING
25-507DR-SS	16" DOUBLE-WALL FULL EXTENSION SLIDE WITH SINGLE RAILING
25-509DR-SS	18" DOUBLE-WALL FULL EXTENSION SLIDE WITH SINGLE RAILING
25-511DR-SS	20" DOUBLE-WALL FULL EXTENSION SLIDE WITH SINGLE RAILING
25-516DR-SS	22" DOUBLE-WALL FULL EXTENSION SLIDE WITH SINGLE RAILING

### KIT INCLUDES:

- #1 - SLIDES LEFT / RIGHT
- #2 - DRAWER SIDES
- #3 - BACK FIXING BRACKETS LEFT / RIGHT
- #4 - FRONT FIXING BRACKET LEFT / RIGHT
- #5 - COVER CAPS LEFT / RIGHT
- #6 - SIDE RAILS LEFT / RIGHT

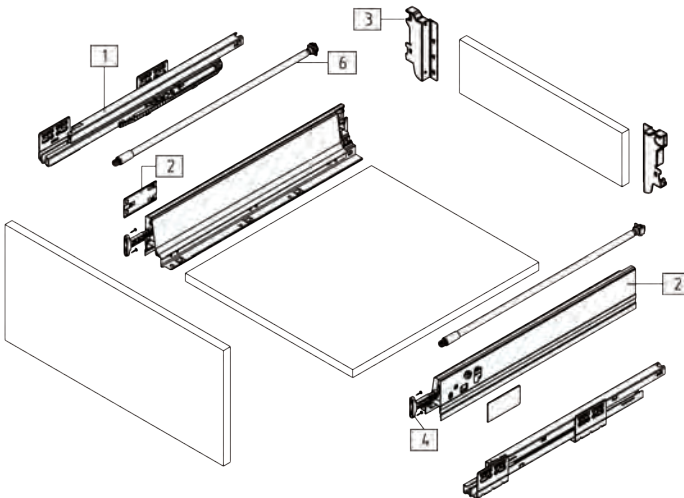

## Stainless Steel Double Wall Undermount Soft-Close

- Concealed, Full Extension
- Dynamic LOAD Capacity: 40kg
- Finish: Stainless Steel
- Tool Free Assembly And Removal Of Drawer
- Silent System Guarantees Smooth Run Without Noise
- Up & Down Adjustment, Left & Right Adjustment

Kitchens

Doors

Kitchen Accessories

Hinges

Drawer Slides

Plywood Melamine

Veneer Edgebanding

Laminate

Solid Surface

Closets

Furniture Hardware

Pulls & Knobs

Lighting

Grommets

Locks, Lock Systems

Molding, Carvings

Tools

Adhesives Solvents Abrasives

Chemicals Staples Screws

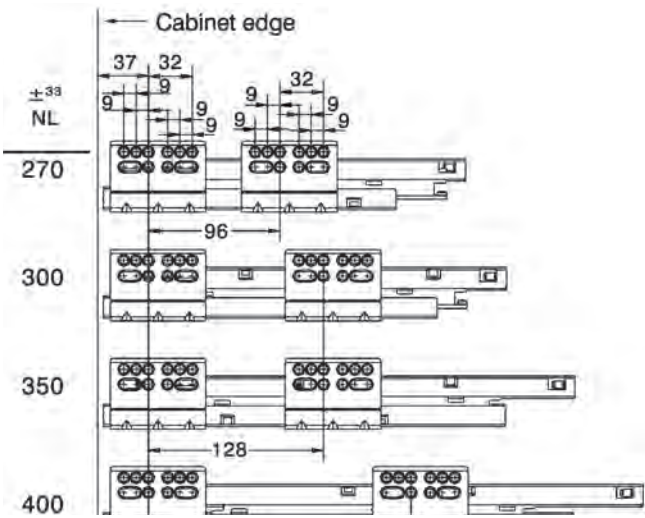

**MEASUREMENTS SHOWN FOR 16mm BOARD**

NL= Nominal Slide Length    LT= Internal cabinet Depth     $LT = NL + 3$

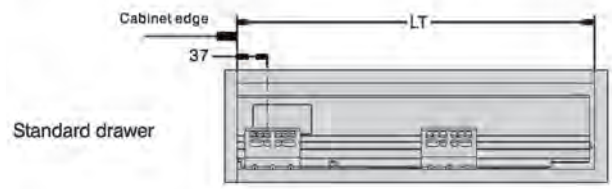

Drawer front Dimensions

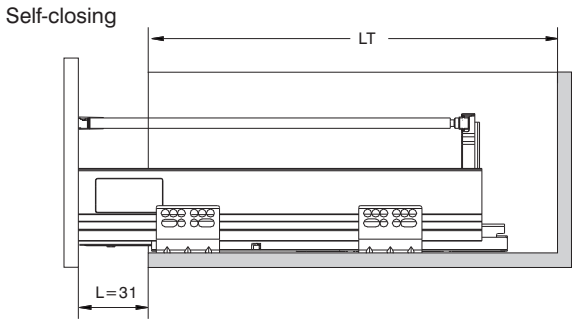
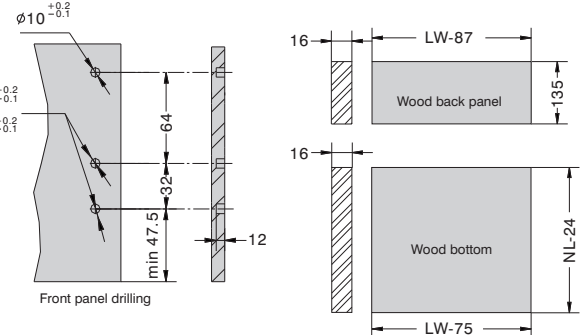

**For 18mm Board**  
Use the following  
Drawer Bottom Width = LW-92

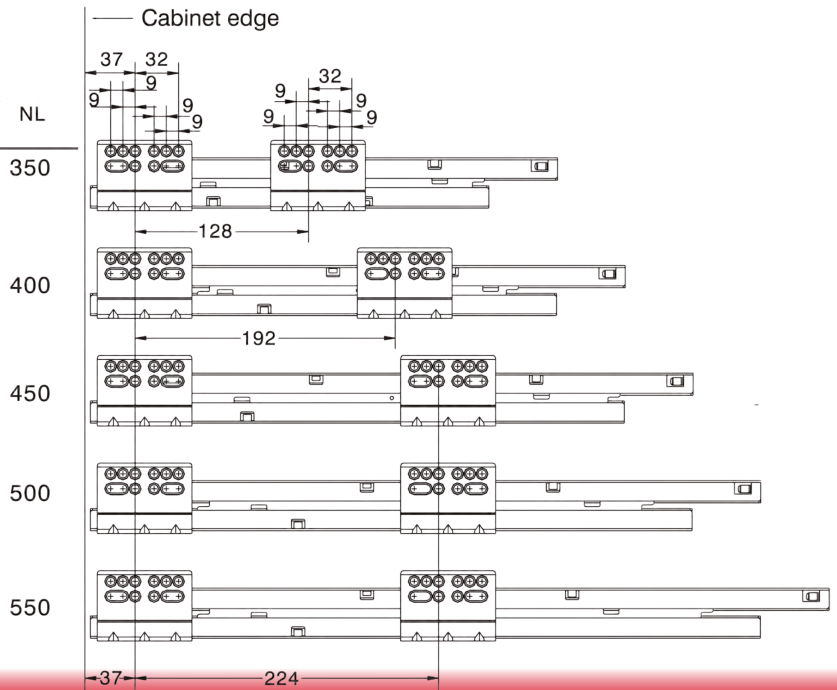

# SLIDES

## Stainless Steel Double Wall Undermount Soft-Close

- Concealed, Full Extension
- Dynamic LOAD Capacity: 40kg
- Finish: Stainless Steel
- Tool Free Assembly And Removal Of Drawer
- Silent System Guarantees Smooth Run Without Noise
- Up & Down Adjustment, Left & Right Adjustment



Note: Rails & Rear Brackets Are Chrome Plated.  
Picture Shown Is For Visual Representation Only

ORDER NUMBER	DESCRIPTION
25-507DR2-SS	16" DOUBLE-WALL FULL EXTENSION SLIDE WITH DOUBLE RAILING
25-511DR2-SS	20" DOUBLE-WALL FULL EXTENSION SLIDE WITH DOUBLE RAILING
25-516DR2-SS	22" DOUBLE-WALL FULL EXTENSION SLIDE WITH DOUBLE RAILING

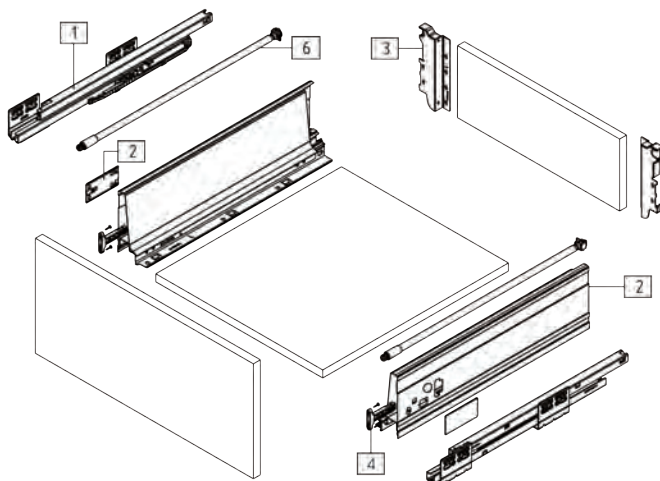

### KIT INCLUDES:

- #1 - SLIDES LEFT / RIGHT
- #2 - DRAWER SIDES
- #3 - BACK FIXING BRACKETS LEFT / RIGHT
- #4 - FRONT FIXING BRACKET LEFT / RIGHT
- #5 - COVER CAPS LEFT / RIGHT
- #6 - 2 SIDE RAILS LEFT / RIGHT





# SLIDES

## Stainless Steel Double Wall Undermount Soft-Close

- Concealed, Full Extension
- Dynamic LOAD Capacity: 40kg
- Finish: Stainless Steel
- Tool Free Assembly And Removal Of Drawer
- Silent System Guarantees Smooth Run Without Noise
- Up & Down Adjustment, Left & Right Adjustment

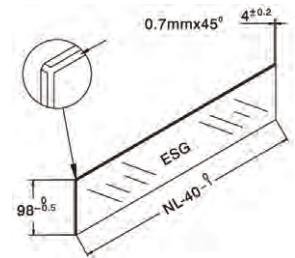

ORDER NUMBER	DESCRIPTION
25-507DG-SS	16" DOUBLE-WALL FULL EXTENSION SLIDE WITH SINGLE RAILING & GLASS SIDES
25-509DG-SS	18" DOUBLE-WALL FULL EXTENSION SLIDE WITH SINGLE RAILING & GLASS SIDES
25-511DG-SS	20" DOUBLE-WALL FULL EXTENSION SLIDE WITH SINGLE RAILING & GLASS SIDES
25-516DG-SS	22" DOUBLE-WALL FULL EXTENSION SLIDE WITH SINGLE RAILING & GLASS SIDES

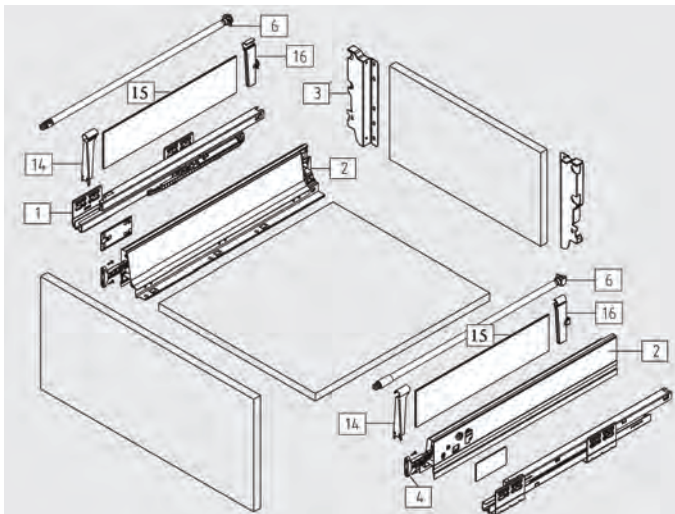

### KIT INCLUDES:

- #1 - SLIDES LEFT / RIGHT
- #2 - DRAWER SIDES & COVER CAPS LEFT / RIGHT
- #3 - BACK FIXING BRACKETS LEFT / RIGHT
- #4 - FRONT FIXING BRACKET LEFT / RIGHT
- #6 - SIDE RAILS LEFT / RIGHT
- #14 - FRONT ADAPTER FOR GLASS
- #15 - GLASS BOXED SIDE LEFT/RIGHT
- #16 - REAR ADAPTER FOR GLASS





# SLIDES

## Stainless Steel Double Wall Undermount Soft-Close

- Concealed, Full Extension
- Dynamic LOAD Capacity: 40kg
- Finish: Stainless Steel
- Tool Free Assembly And Removal Of Drawer
- Silent System Guarantees Smooth Run Without Noise
- Up & Down Adjustment, Left & Right Adjustment



ORDER NUMBER	DESCRIPTION
25-500	20" DOUBLE-WALL SINK DRAWER FULL EXTENSION SLIDE

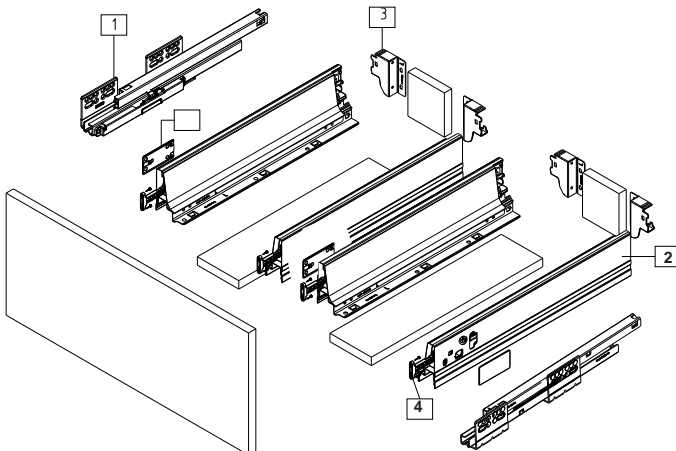

### KIT INCLUDES:

- #1 - SLIDES LEFT / RIGHT
- #2 - DRAWER SIDES & COVER CAPS LEFT / RIGHT
- #3 - BACK FIXING BRACKETS LEFT / RIGHT
- #4 - FRONT FIXING BRACKET LEFT / RIGHT







## Stainless Steel Double Wall Undermount Soft-Close

Kitchens

### Stainless Steel Under mount Soft Close Accessories

Doors

Kitchen Accessories

Hinges

Drawer Slides

Plywood Melamine

Veneer Edgebanding

Laminate

Solid Surface

Closets

Furniture Hardware

Pulls & Knobs

Lighting

Grommets

Locks, Lock Systems

Molding, Carvings

Tools

Adhesives Solvents Abrasives

Chemicals Staples Screws

ORDER NUMBER	DESCRIPTION	DIA.
H6.01042D	DOUBLE-WALL CROSS RAIL CONNECTOR	8
H6.01046D	DOUBLE-WALL DIVIDER RAIL CONNECTOR	11
H6.01043D	DOUBLE-WALL DIVIDER RAIL CONNECTOR 1100MM CUT TO SIZE	7
H6.01047D	DOUBLE-WALL DIVIDER RAIL	12
H6.01048D	DOUBLE-WALL CONNECTOR FOR METAL SIDES	20
H6.01500D	ANTI-SLIP MAT 500MM	22

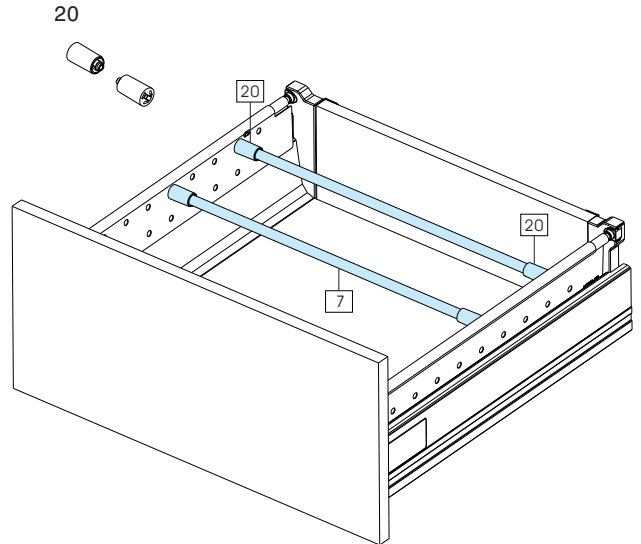
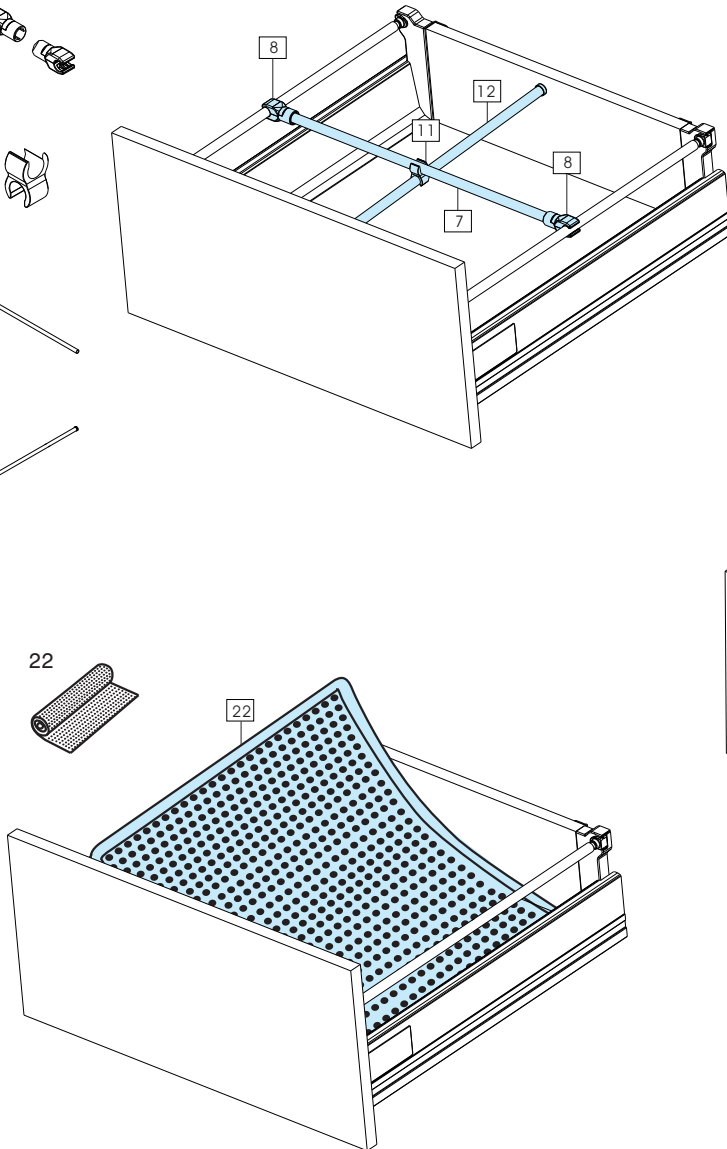
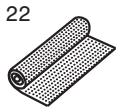
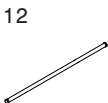
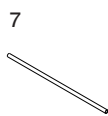
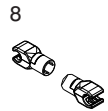

# SLIDES



# Double Wall Drawer Slides

## Double Wall Undermount Soft-Close

- Concealed, Full Extension
- Dynamic LOAD capacity: 40kg
- Finish: Metallic Grey
- Tool Free Assembly and Removal of Drawer
- Silent System Guarantees Smooth Run Without Noise
- Up & Down Adjustment, Left & Right Adjustment



### ORDER NUMBER

### DESCRIPTION

25-505D	14" DOUBLE-WALL FULL EXTENSION SLIDE
25-512D	18" DOUBLE-WALL FULL EXTENSION SLIDE
25-514D	20" DOUBLE-WALL FULL EXTENSION SLIDE
25-516D	22" DOUBLE-WALL FULL EXTENSION SLIDE

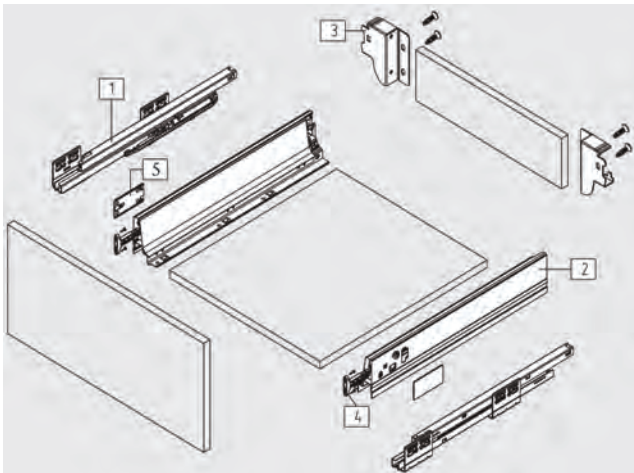

### KIT INCLUDES:

- #1 - SLIDES LEFT / RIGHT
- #2 - DRAWER SIDES
- #3 - BACK FIXING BRACKETS LEFT / RIGHT
- #4 - FRONT FIXING BRACKET LEFT / RIGHT
- #5 - COVER CAPS LEFT / RIGHT

## Double Wall Undermount Soft-Close

- Concealed, Full Extension
- Dynamic LOAD capacity: 40kg
- Finish: Metallic Grey
- Tool Free Assembly and Removal of Drawer
- Silent System Guarantees Smooth Run Without Noise
- Up & Down Adjustment, Left & Right Adjustment

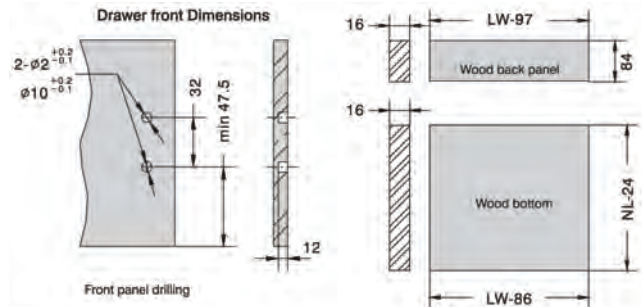
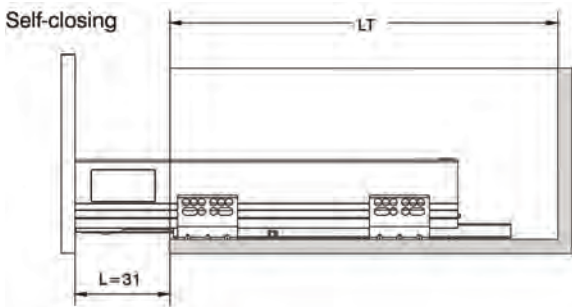

### MEASUREMENTS SHOWN FOR 16mm BOARD

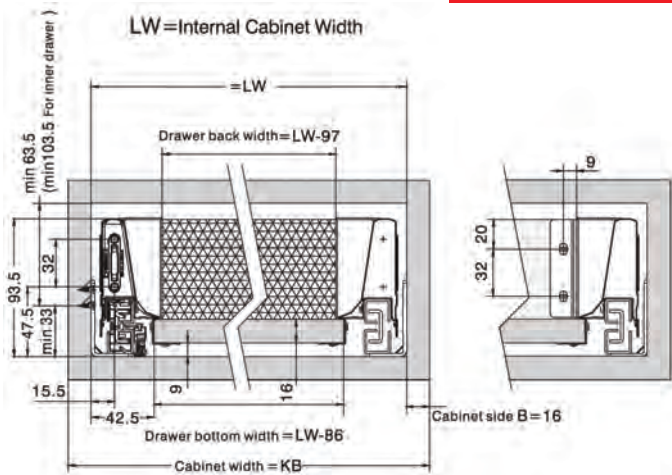

NL = Nominal Slide Length    LT = Internal cabinet Depth    LT = NL + 3

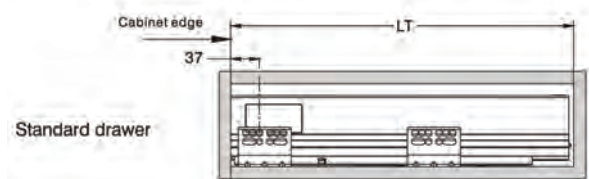

**For 18mm Board**  
Use the following  
Drawer Bottom Width = LW-92

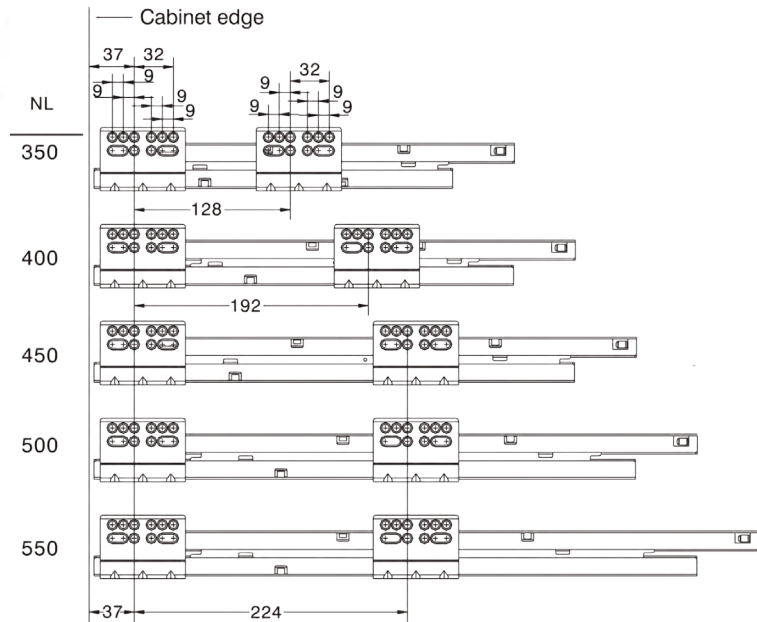

- Kitchens
- Doors
- Kitchen Accessories
- Hinges
- Drawer Slides
- Plywood Melamine
- Veneer Edgebanding
- Laminate
- Solid Surface

- Joists
- Furniture Hardware
- Knobs & Pulls
- Lighting
- Grommets
- Locks, Lock Systems
- Molding, Carvings
- Tools
- Adhesives Solvents Abrasives
- Chemicals Staples Screws

## Double Wall Undermount Soft-Close

- Concealed, Full Extension
- Dynamic LOAD capacity: 40kg
- Finish: Metallic Grey
- Tool Free Assembly and Removal of Drawer
- Silent System Guarantees Smooth Run Without Noise
- Up & Down Adjustment, Left & Right Adjustment



### ORDER NUMBER

### DESCRIPTION

**25-509DR**

18" DOUBLE-WALL FULL EXTENSION SLIDE WITH SINGLE RAILING

**25-511DR**

20" DOUBLE-WALL FULL EXTENSION SLIDE WITH SINGLE RAILING

**25-516DR**

22" DOUBLE-WALL FULL EXTENSION SLIDE WITH SINGLE RAILING

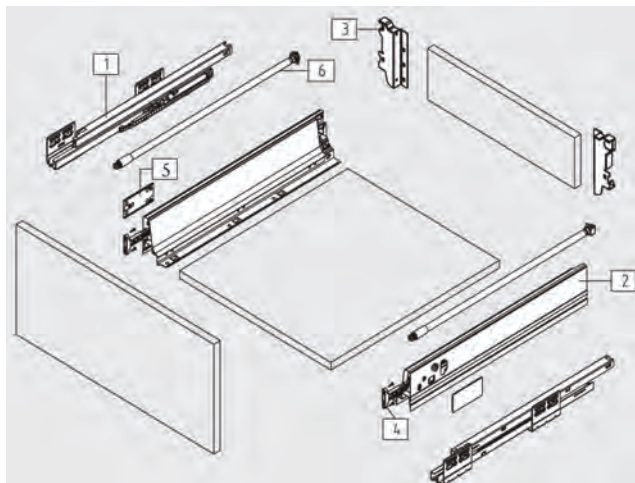

### KIT INCLUDES:

- #1 - SLIDES LEFT / RIGHT
- #2 - DRAWER SIDES
- #3 - BACK FIXING BRACKETS LEFT / RIGHT
- #4 - FRONT FIXING BRACKET LEFT / RIGHT
- #5 - COVER CAPS LEFT / RIGHT
- #6 - SIDE RAILS LEFT / RIGHT

Kitchens

Doors

Kitchen Accessories

Hinges

**Drawer Slides**

Plywood Melamine

Veneer Edgebanding

Laminate

Solid Surface

Closets

Furniture Hardware

Pulls & Knobs

Lighting

Grommets

Locks, Lock Systems

Molding, Carvings

Tools

Adhesives Solvents Abrasives

Chemicals Staples Screws

## Double Wall Undermount Soft-Close

- Concealed, Full Extension
- Dynamic LOAD capacity: 40kg
- Finish: Metallic Grey
- Tool Free Assembly and Removal of Drawer
- Silent System Guarantees Smooth Run Without Noise
- Up & Down Adjustment, Left & Right Adjustment

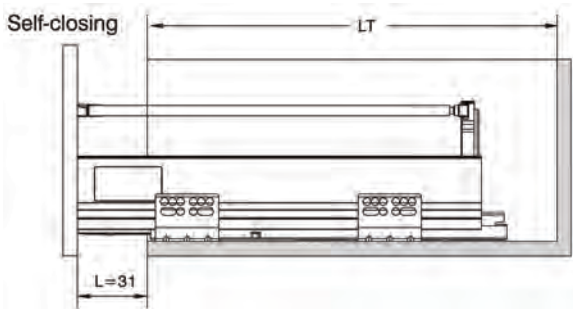

Drawer front Dimensions

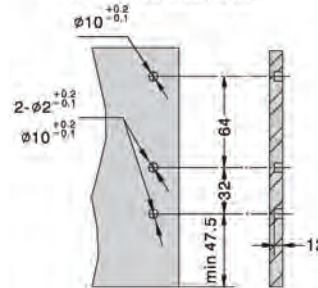

Front panel drilling

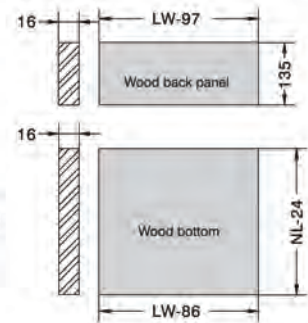

LW=Internal Cabinet Width

### MEASUREMENTS SHOWN FOR 16mm BOARD

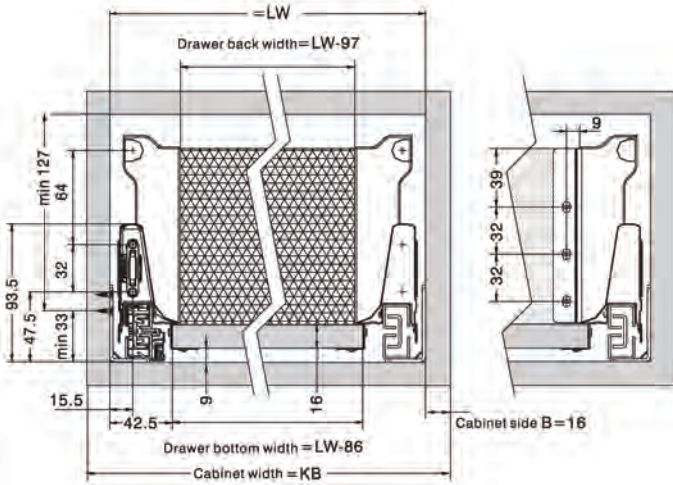

NL= Nominal Slide Length    LT= Internal cabinet Depth     $LT = NL + 3$

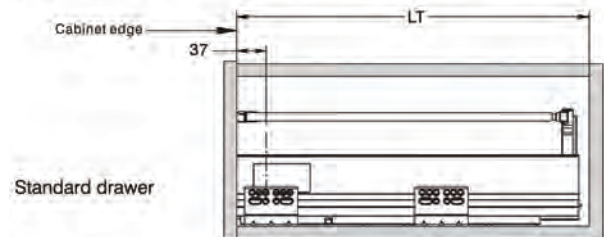

**For 18mm Board**  
Use the following  
Drawer Bottom Width = LW-92

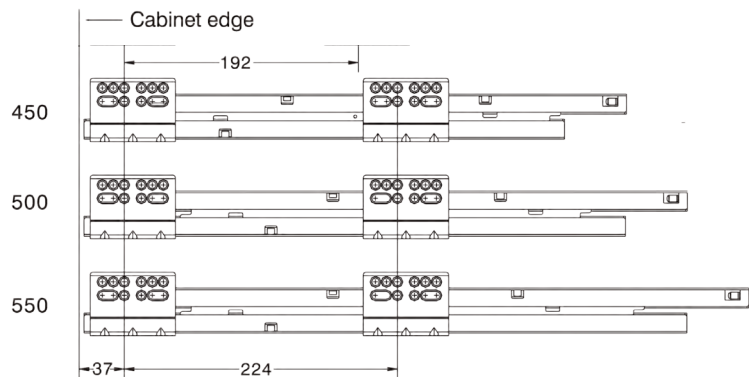

Kitchens

Doors

Kitchen Accessories

Hinges

Drawer Slides

Plywood Melamine

Veneer Edgebanding

Laminate

Solid Surface

Closets

Furniture Hardware

Pulls & Knobs

Lighting

Grommets

Locks, Lock Systems

Molding, Carvings

Tools

Adhesives Solvents Abrasives

Chemicals Staples Screws

# SLIDES

## Double Wall Undermount Soft-Close

- Concealed, Full Extension
- Dynamic LOAD capacity: 40kg
- Finish: Metallic Grey
- Tool Free Assembly and Removal of Drawer
- Silent System Guarantees Smooth Run Without Noise
- Up & Down Adjustment, Left & Right Adjustment



### ORDER NUMBER

### DESCRIPTION

**25-509DR2**

18" DOUBLE-WALL FULL EXTENSION SLIDE WITH DOUBLE RAILING

**25-511DR2**

20" DOUBLE-WALL FULL EXTENSION SLIDE WITH DOUBLE RAILING

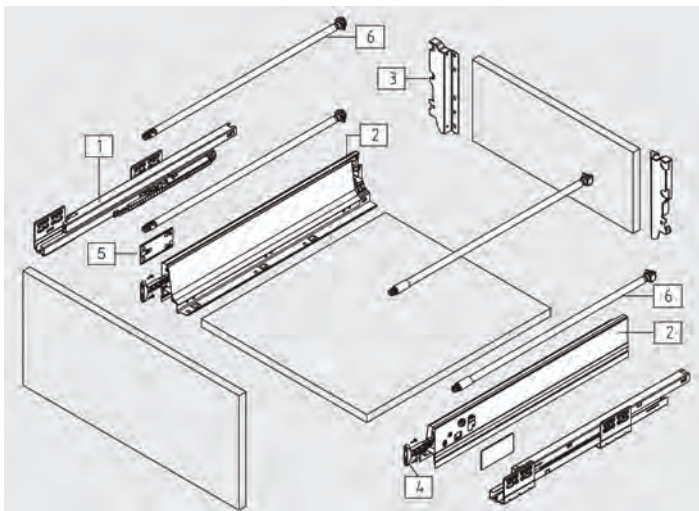

### KIT INCLUDES:

- #1 - SLIDES LEFT / RIGHT
- #2 - DRAWER SIDES
- #3 - BACK FIXING BRACKETS LEFT / RIGHT
- #4 - FRONT FIXING BRACKET LEFT / RIGHT
- #5 - COVER CAPS LEFT / RIGHT
- #6 - 2 SIDE RAILS LEFT / RIGHT



## Double Wall Undermount Soft-Close

- Concealed, Full Extension
- Dynamic LOAD capacity: 40kg
- Finish: Metallic Grey
- Tool Free Assembly and Removal of Drawer
- Silent System Guarantees Smooth Run Without Noise
- Up & Down Adjustment, Left & Right Adjustment

Kitchens

Doors

Kitchen Accessories

Hinges

Drawer Slides

Plywood Melamine

Veneer Edgebanding

Laminate

Solid Surface

Closets

Furniture Hardware

Pulls & Knobs

Lighting

Grommets

Locks, Lock Systems

Molding, Carvings

Tools

Adhesives Solvents Abrasives

Chemicals Staples Screws

NL = Nominal Slide Length    LT = Internal cabinet Depth     $LT = NL + 3$

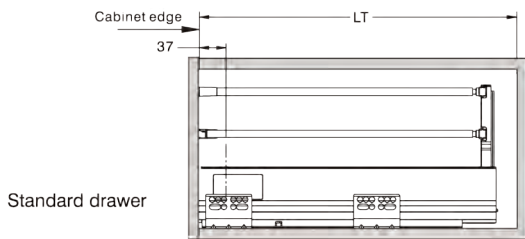

Drawer front Dimensions

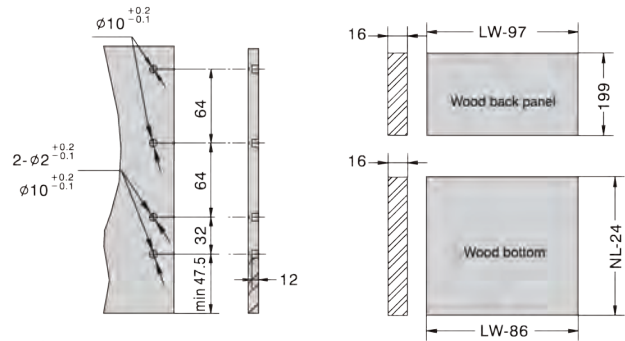

### MEASUREMENTS SHOWN FOR 16mm BOARD

LW = Internal Cabinet Width

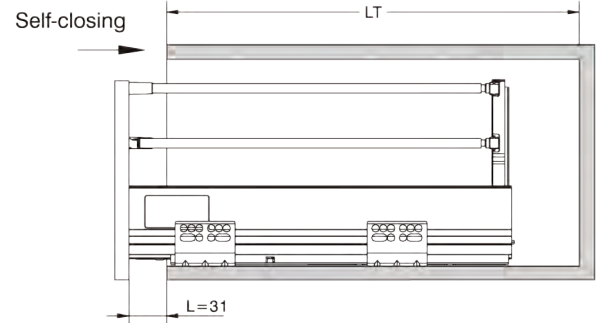
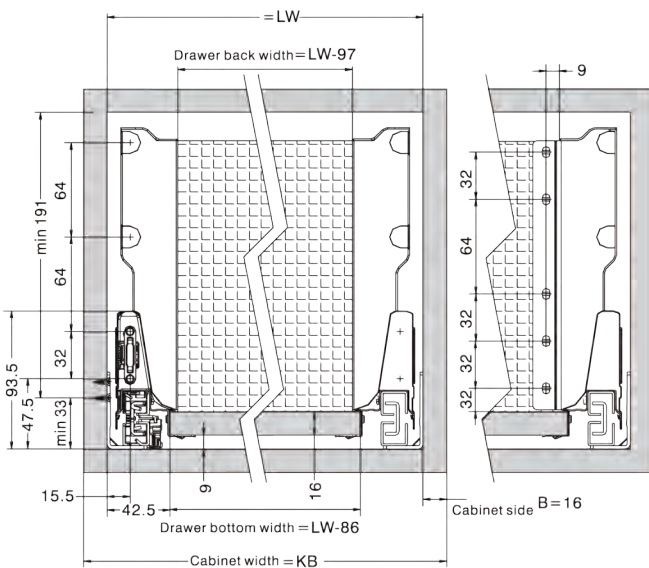

**For 18mm Board**  
Use the following  
Drawer Bottom Width = LW-92

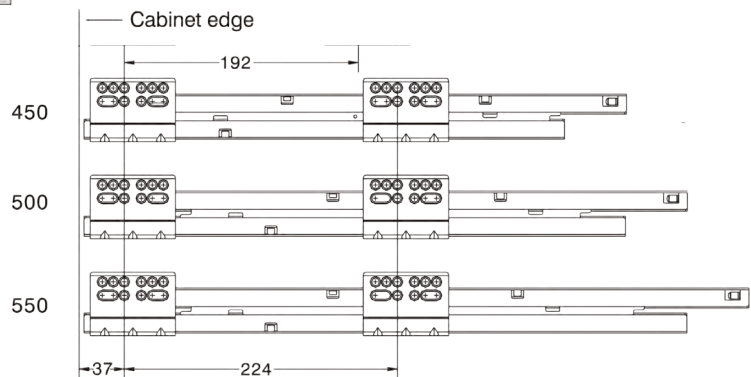



## Double Wall Undermount Soft-Close

- Concealed, Full Extension
- Dynamic LOAD capacity: 40kg
- Finish: Metallic Grey
- Tool Free Assembly and Removal of Drawer
- Silent System Guarantees Smooth Run Without Noise
- Up & Down Adjustment, Left & Right Adjustment

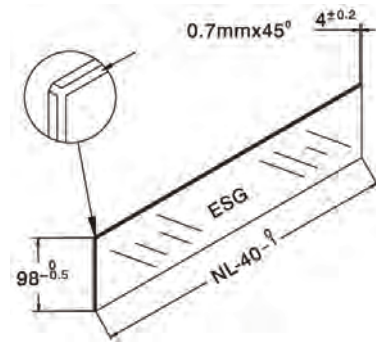

ORDER NUMBER	DESCRIPTION
--------------	-------------

25-505DG	14" DOUBLE-WALL FULL EXTENSION SLIDE WITH SINGLE RAILING & GLASS SIDES
25-507DG	16" DOUBLE-WALL FULL EXTENSION SLIDE WITH SINGLE RAILING & GLASS SIDES
25-509DG	18" DOUBLE-WALL FULL EXTENSION SLIDE WITH SINGLE RAILING & GLASS SIDES
25-511DG	20" DOUBLE-WALL FULL EXTENSION SLIDE WITH SINGLE RAILING & GLASS SIDES
25-516DG	22" DOUBLE-WALL FULL EXTENSION SLIDE WITH SINGLE RAILING & GLASS SIDES

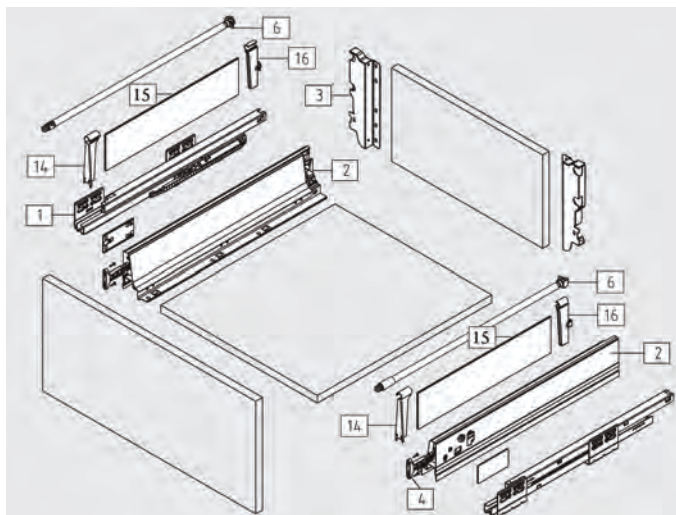

- #1 - SLIDES LEFT / RIGHT
- #2 - DRAWER SIDES & COVER CAPS LEFT / RIGHT
- #3 - BACK FIXING BRACKETS LEFT / RIGHT
- #4 - FRONT FIXING BRACKET LEFT / RIGHT
- #6 - SIDE RAILS LEFT / RIGHT
- #14 - FRONT ADAPTER FOR GLASS
- #15 - GLASS BOXESIDE LEFT/RIGHT
- #16 - REAR ADAPTER FOR GLASS

## Double Wall Undermount Soft-Close

- Concealed, Full Extension
- Dynamic LOAD capacity: 40kg
- Finish: Metallic Grey
- Tool Free Assembly and Removal of Drawer
- Silent System Guarantees Smooth Run Without Noise
- Up & Down Adjustment, Left & Right Adjustment

Kitchens

Doors

Kitchen Accessories

Hinges

Drawer Slides

Plywood Melamine

Veneer Edgbanding

Laminate

Solid Surface

Closets

Furniture Hardware

Pulls & Knobs

Lighting

Grommets

Locks, Lock Systems

Molding, Carvings

Tools

Adhesives Solvents Abrasives

Chemicals Staples Screws

NL = Nominal Slide Length    LT = Internal cabinet Depth     $LT = NL + 3$

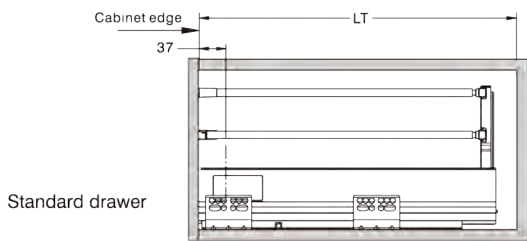

Drawer front Dimensions

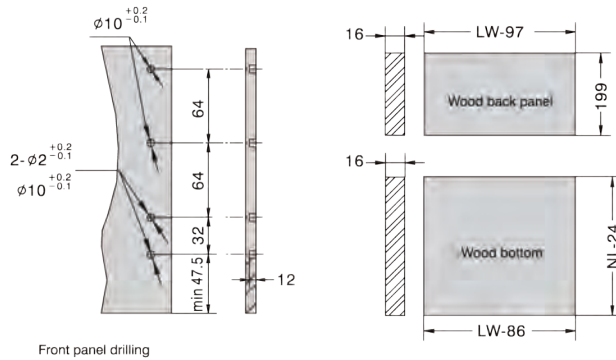

Front panel drilling

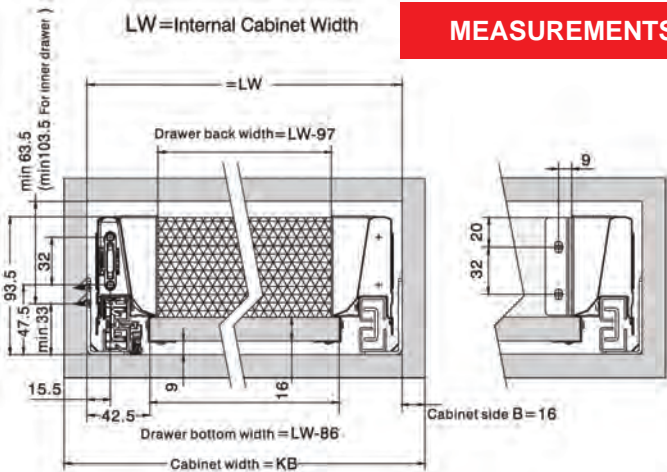

### MEASUREMENTS SHOWN FOR 16mm BOARD

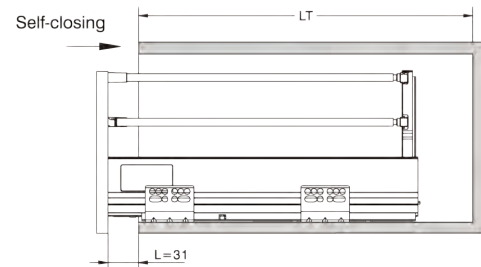

**For 18mm Board**  
Use the following  
Drawer Bottom Width = LW-92

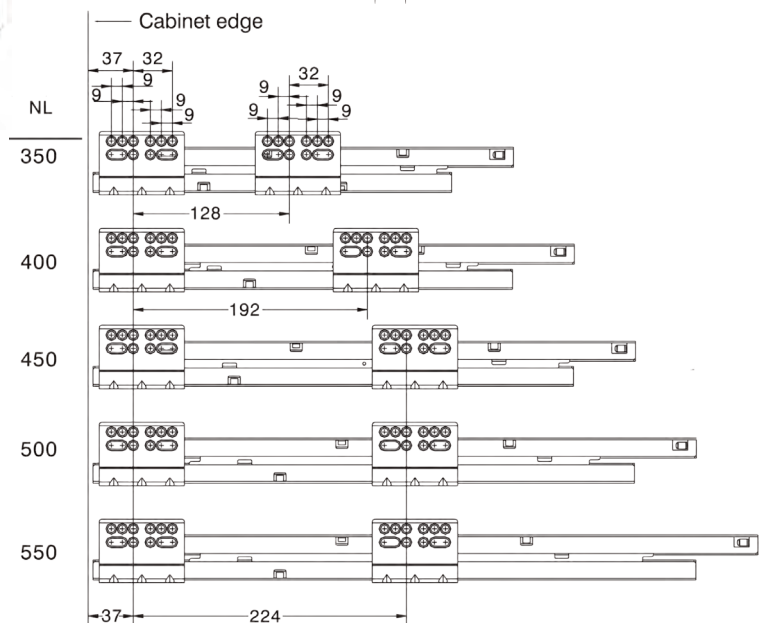

# SLIDES

## Double Wall Undermount Soft-Close

Kitchens

Doors

Kitchen  
Accessories

Hinges

Drawer  
Slides

Plywood  
Melamine

Veneer  
Edgebanding

Laminate

Solid  
Surface

Closets

Furniture  
Hardware

Pulls  
&  
Knobs

Lighting

Grommets

Locks,  
Lock  
Systems

Molding,  
Carvings

Tools

Adhesives  
Solvents  
Abrasives

Chemicals  
Staples  
Screws

### Box Side Option

- Metal-Box Side Option

- Use With **25-509DR, 25-511DR, 25-516DR, 25-509DR2, or 25-511DR2**

- Finish: Metallic Gray

- Tool Free Assembly And Removal Of Side

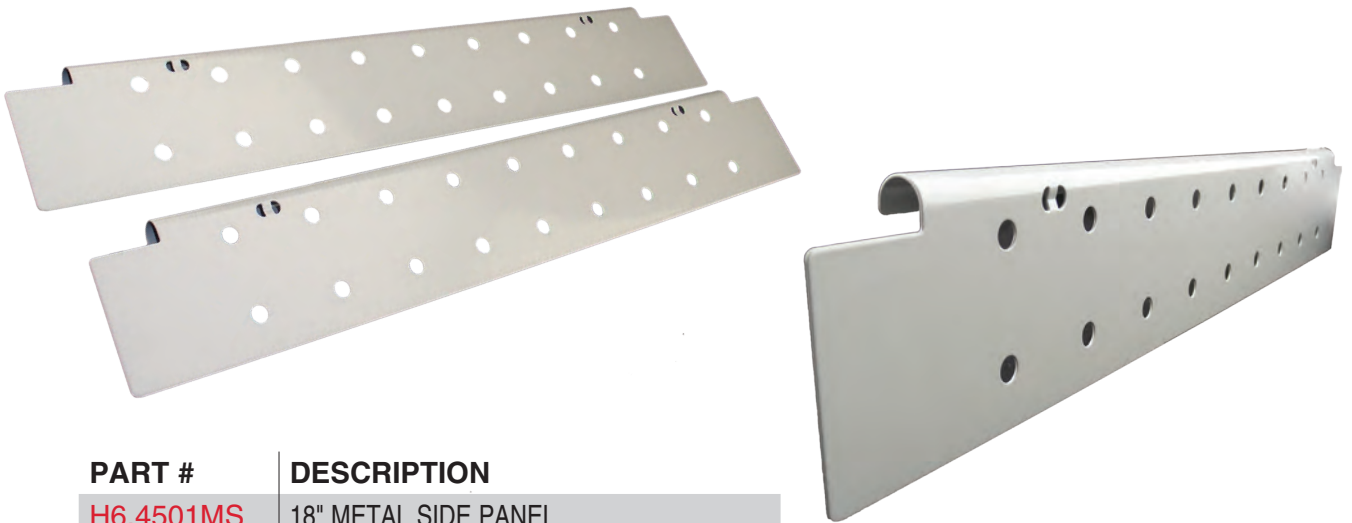

PART #	DESCRIPTION
H6.4501MS	18" METAL SIDE PANEL
H6.5001MS	20" METAL SIDE PANEL
H6.5501MS	22" METAL SIDE PANEL

USE WITH **25-509DR, 25-511DR, 25-516DR, 25-509DR2,**  
Or **25-511DR2** DOUBLE WALL SLIDE



## Double Wall Undermount Soft-Close

### Under mount Soft Close Accessories

PART #	DESCRIPTION	DIA.
H6.01042D	DOUBLE-WALL CROSS RAIL CONNECTOR	8
H6.01046D	DOUBLE-WALL DIVIDER RAIL CONNECTOR	11
H6.01043D	DOUBLE-WALL DIVIDER RAIL CONNECTOR 1100MM CUT TO SIZE	7
H6.01047D	DOUBLE-WALL DIVIDER RAIL	12
H6.01048D	DOUBLE-WALL CONNECTOR FOR METAL SIDES	20
H6.01500D	ANTI-SLIP MAT 500MM	22

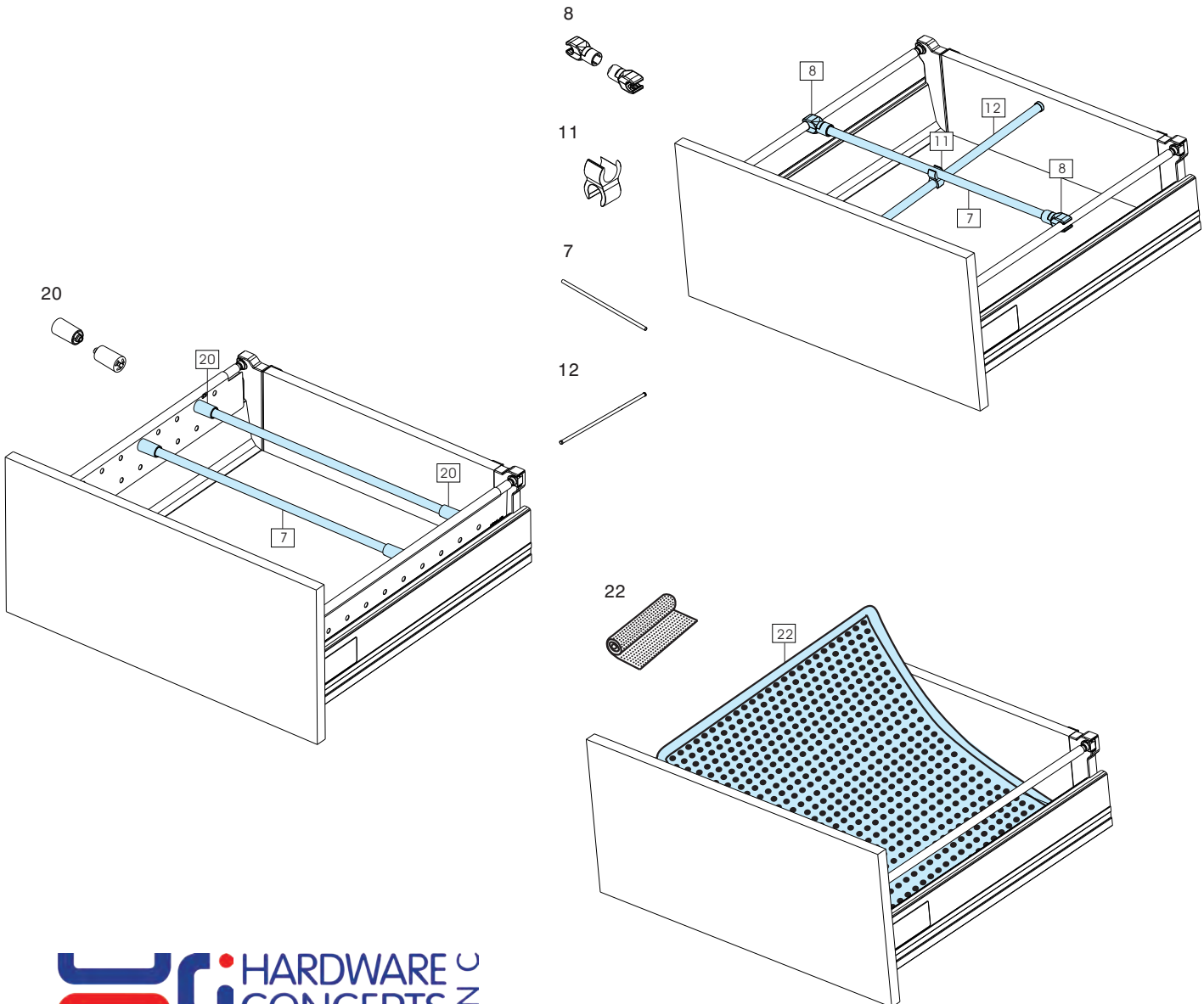

Kitchens

Doors

Kitchen  
Accessories

Hinges

Drawer  
Slides

Plywood  
Melamine

Veneer  
Edgebanding

Laminate

Solid  
Surface

Closets

Furniture  
Hardware

Pulls  
&  
Knobs

Lighting

Grommets

Locks,  
Lock  
Systems

Molding,  
Carvings

Tools

Adhesives  
Solvents  
Abrasives

Chemicals  
Staples  
Screws

## Double Wall Undermount Soft-Close

Kitchens

Doors

Kitchen  
Accessories

Hinges

Drawer  
Slides

Plywood  
Melamine

Veneer  
Edgebanding

Laminate

Solid  
Surface

Closets

Furniture  
Hardware

Pulls  
&  
Knobs

Lighting

Grommets

Locks,  
Lock  
Systems

Molding,  
Carvings

Tools

Adhesives  
Solvents  
Abrasives

Chemicals  
Staples  
Screws

### Installation Jig

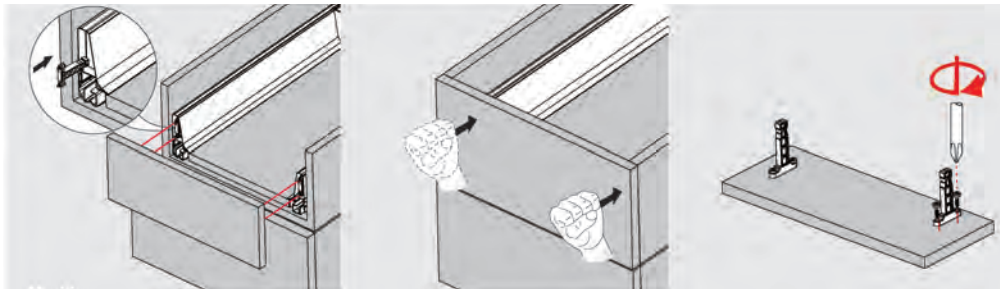

PART #	DESCRIPTION
H6.003U	DRILLING JIG
USE WITH 25-509DR, 25-511DR, 25-516DR, 25-509DR2, Or 25-511DR2 DOUBLE WALL SLIDE	

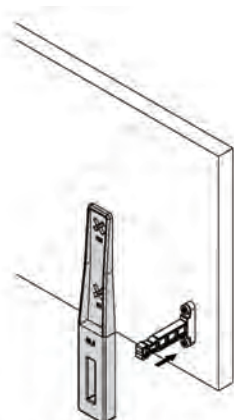

1 Fix front bracket

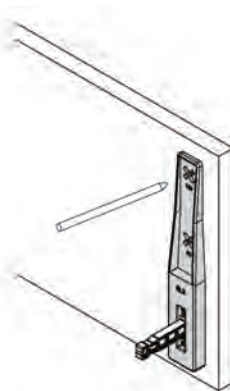

2 Mark the position of the railings

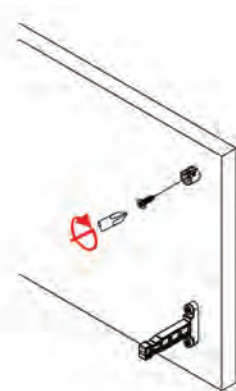

3 Fix the dowel of the railing with screw into the drawer front

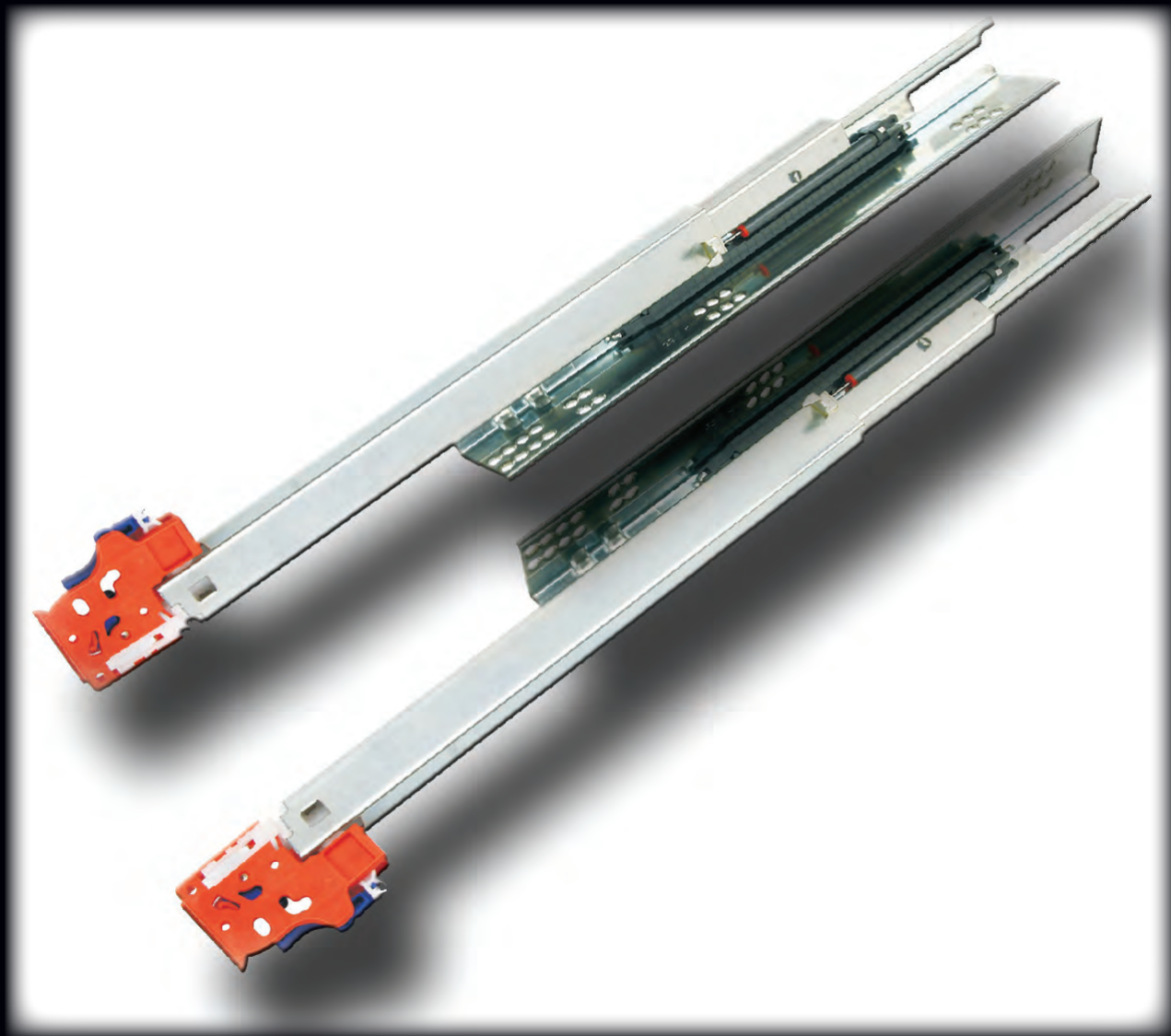

Soft Close Drawer Slides



## Soft-Close Undermount

Full Extension Undermount Slides for Frame and Frameless Cabinets  
(with locking device and damper)  
(Max Drawer Side Thickness: 16mm)

- LOAD capacity:25kg
- Finish: zinc plated
- Length:229-533mm
- Full extension
- Tool free assembly and removal of drawer
- Silent system guarantees smooth run without noise
- Drawer height adjustment: 0 - +3mm



ORDER NUMBER	DESCRIPTION
<b>25-911</b>	LEFT & RIGHT FRONT RELEASE BRACKET
<b>25-905</b>	12" SOFT CLOSE FULL EXTENSION SLIDE
<b>25-907</b>	15" SOFT CLOSE FULL EXTENSION SLIDE
<b>25-909</b>	18" SOFT CLOSE FULL EXTENSION SLIDE
<b>25-910</b>	21" SOFT CLOSE FULL EXTENSION SLIDE
<b>PUSH TO OPEN</b>	
<b>25-905PUSH</b>	12" SOFT CLOSE FULL EXTENSION SLIDE
<b>25-907PUSH</b>	15" SOFT CLOSE FULL EXTENSION SLIDE
<b>25-909PUSH</b>	18" SOFT CLOSE FULL EXTENSION SLIDE
<b>25-910PUSH</b>	21" SOFT CLOSE FULL EXTENSION SLIDE

## Soft-Close Undermount

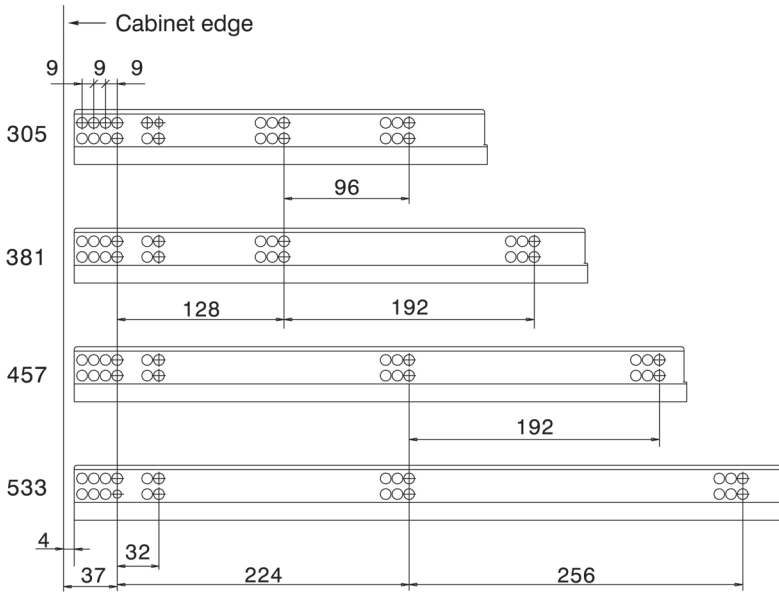

SKW = Internal Drawer Width      LW = Internal Cabinet Width

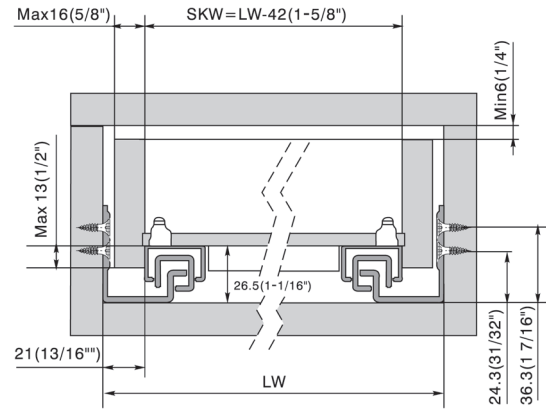

NL = Nominal Slide Length      LT = Internal cabinet Depth

Inner drawer

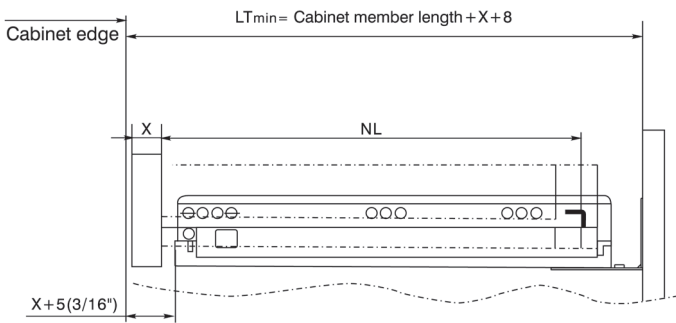

Standard drawer

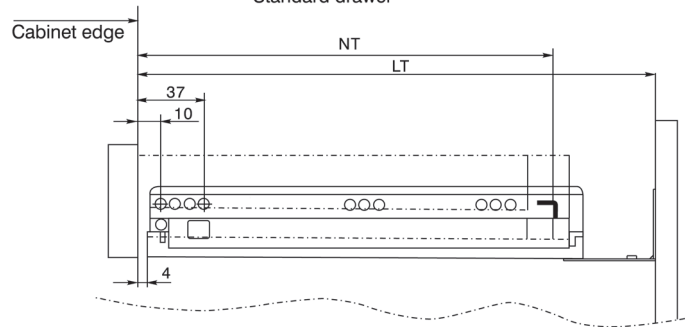

Plastic Rear Mounting Bracket

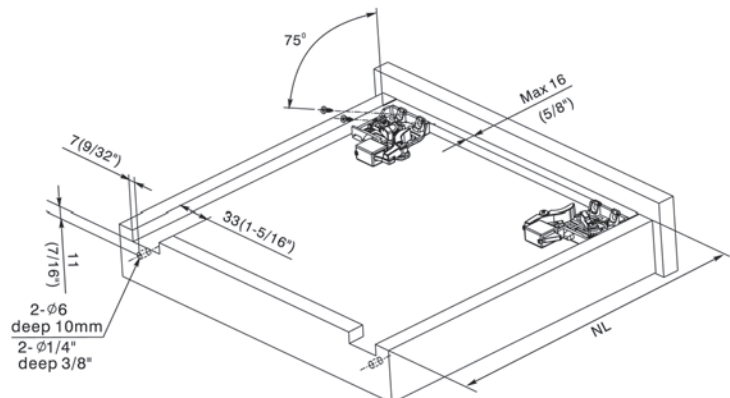
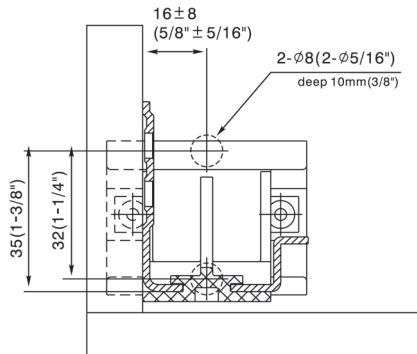

Kitchens

Doors

Kitchen  
Accessories

Hinges

Drawer  
Slides

Plywood  
Melamine

Veneer  
Edgebanding

Laminate

Solid  
Surface

Closets

Furniture  
Hardware

Pulls  
&  
Knobs

Lighting

Grommets

Locks,  
Lock  
Systems

Molding,  
Carvings

Tools

Adhesives  
Solvents  
Abrasives

Chemicals  
Staples  
Screws



# SLIDES

## Soft-Close Full Extension Side Mount

Kitchens

Doors

Kitchen  
Accessories

Hinges

Drawer  
Slides

Plywood  
Melamine

Veneer  
Edgebanding

Laminate

Solid  
Surface

Closets

Furniture  
Hardware

Pulls  
&  
Knobs

Lighting

Grommets

Locks,  
Lock  
Systems

Molding,  
Carvings

Tools

Adhesives  
Solvents  
Abrasives

Chemicals  
Staples  
Screws

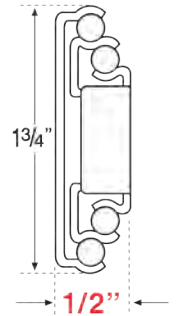
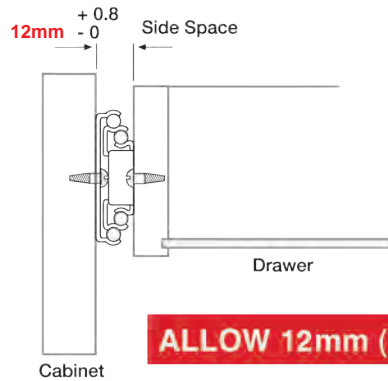
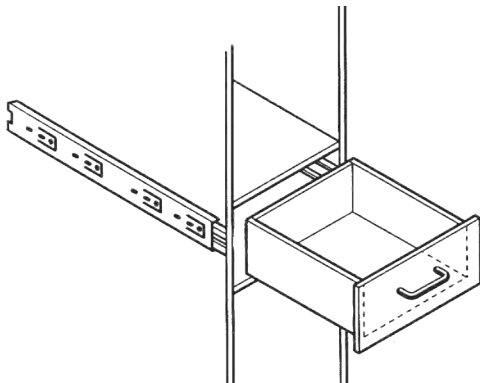
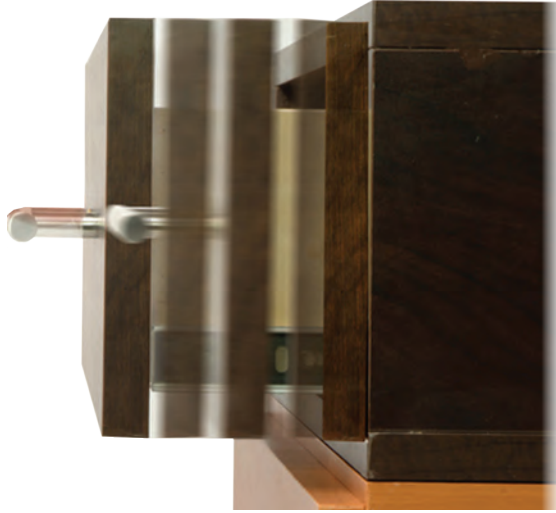

**ALLOW 12mm (1/2")**

### ORDER NUMBER

### DESCRIPTION

**25-240**

12" SOFT-CLOSING FULL EXTENSION SLIDE

**25-242**

14" SOFT-CLOSING FULL EXTENSION SLIDE

**25-244**

16" SOFT-CLOSING FULL EXTENSION SLIDE

**25-246**

18" SOFT-CLOSING FULL EXTENSION SLIDE

**25-248**

20" SOFT-CLOSING FULL EXTENSION SLIDE

**25-250**

22" SOFT-CLOSING FULL EXTENSION SLIDE



## 100 Lb. Full Extension Drawer Slide

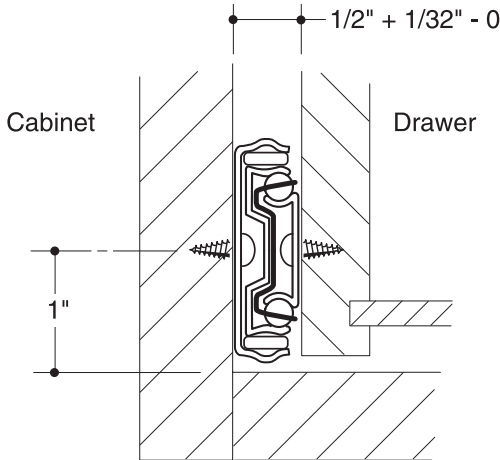

### ORDER NUMBERS

10"	.....	25-130
12"	.....	25-112
14"	.....	25-114
16"	.....	25-116
18"	.....	25-118
20"	.....	25-120
22"	.....	25-122
24"	.....	25-124

### Description

- Non-handed design permits mounting to right or left side of cabinet
- Full 32 mm hole pattern accommodates screw mounting at front, center and rear positions to securely fasten slide in place
- Anochrome finish with lacquer provides for superior corrosion resistance - over 100 hours salt spray test

100 lb. Capacity – Chrome Plated



## 150 Lb. Full Extension Drawer Slide

150 lb. Capacity, Heavy Duty, Nylon Wheel, Steel Ball Bearings

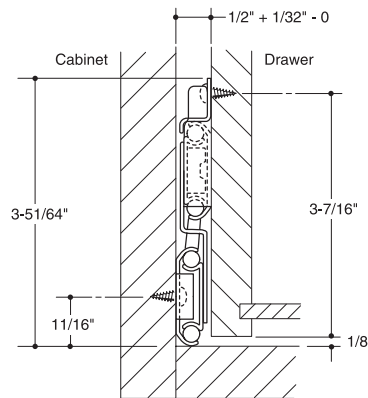

### ORDER NUMBERS

16"	.....	25-176
18"	.....	25-178
20"	.....	25-180
22"	.....	25-182

### Description

- Side mount, 3-51/64" height
- Requires 1/2", + 1/32", - 0" clearance on each side
- Cold rolled steel, zinc plated
- Non-handed "Quick-disconnect" drawer member, positive lock-in device to prevent drawers from falling out in shipping



Kitchens

Doors

Kitchen Accessories

Hinges

Drawer Slides

Plywood Melamine

Veneer Edgbanding

Laminate

Solid Surface

Closets

Furniture Hardware

Pulls & Knobs

Lighting

Grommets

Locks, Lock Systems

Molding, Carvings

Tools

Adhesives Solvents Abrasives

Chemicals Staples Screws

# SLIDES

## 500 Lb. Super Duty Drawer Slides

Kitchens  
Doors  
Kitchen Accessories

### Features:

- Spring loaded locking system ensures positive lock
- Precision ball bearings
- Cushioned in-stop for noise absorption
- Non-disconnect
- Steel ball cage for higher load and impact implications

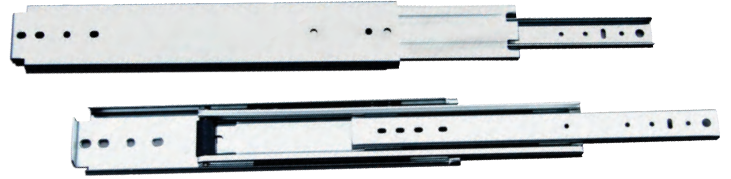

Load Rating: 300-500 lbs (136-227 kg)/pair\*

- \* 300 lbs (136 kg)-75,000 cycles,
- \* 500 lbs (227 kg)-10,000 cycles

### ORDER NUMBERS

12" .....	<b>25-352</b>	22" .....	<b>25-362</b>
14" .....	<b>25-354</b>	24" .....	<b>25-364</b>
16" .....	<b>25-356</b>	26" .....	<b>25-366</b>
18" .....	<b>25-358</b>	28" .....	<b>25-368</b>
20" .....	<b>25-360</b>	30" .....	<b>25-370</b>

Side Space: 3/4" (19 mm)

Drawer Slides

Plywood Melamine

Veneer Edgebanding

Laminate

Solid Surface

Closets

Furniture Hardware

Pulls & Knobs

Lighting

Grommets

Locks, Lock Systems

Molding, Carvings

Tools

Adhesives Solvents Abrasives

Chemicals Staples Screws

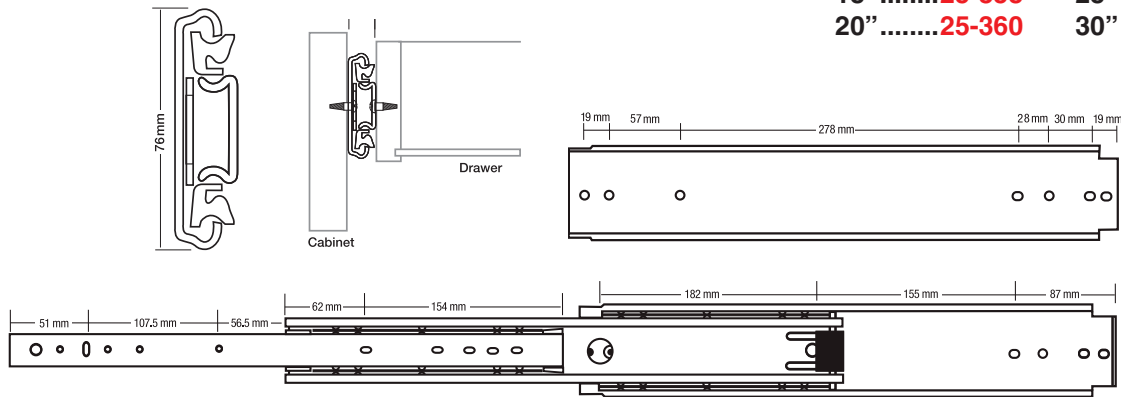

## 400 Lb. Heavy Duty Drawer Slides

### LOAD rating based on application:

- Modest use: 500 lbs.
- Normal use: 400 lbs.
- Vehicular use: 300 lbs.
- Flat mount use: 180 lbs.

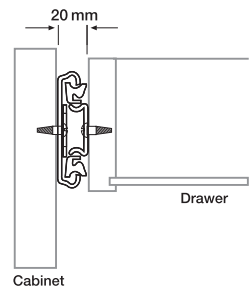

### ORDER NUMBERS

16" .....	<b>25-476</b>	24" .....	<b>25-484</b>
18" .....	<b>25-478</b>	26" .....	<b>25-486</b>
20" .....	<b>25-480</b>	28" .....	<b>25-488</b>
22" .....	<b>25-482</b>		

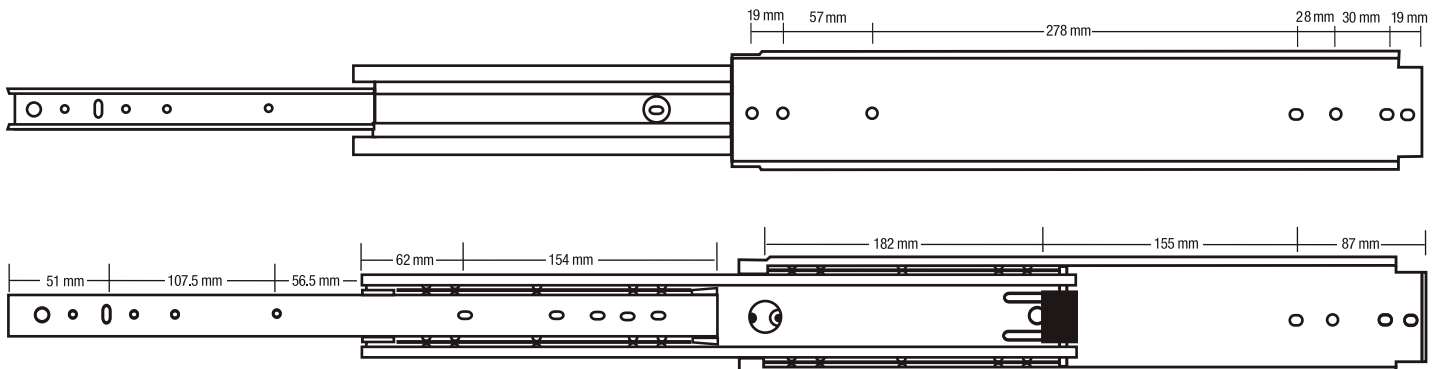

# SLIDES

## 100 Lb. Full Extension Drawer Slide

- Ball Bearings
- 32mm Mounting System
- 100 Lb. Capacity
- 1" Over Travel



### HOLE PATTERN

TRAVEL	A	B	C	D	E	F
275	248	160			169	
325	298	224			96	128
375	348			224	128	128
425	398	224		288	128	192
475	448	224	352		160	192
525	498	416\224	352		192	224
575	548	224	352	416	224	224
625	598	224	352	480	224	288

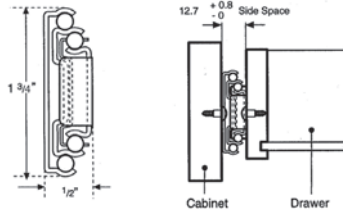
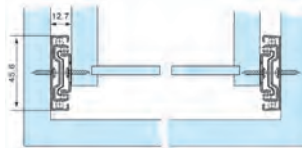

### ORDER NUMBERS

	Chrome	Black
10" .....	25-220	25-320
12" .....	25-222	25-322
14" .....	25-224	25-324
16" .....	25-226	25-326
18" .....	25-228	25-328
20" .....	25-230	25-332
22" .....	25-232	25-334
24" .....	25-234	25-336

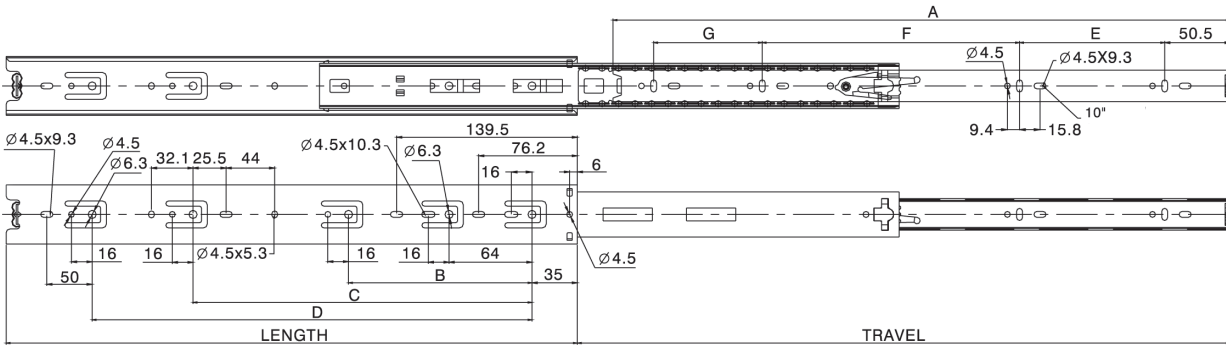

## Rear Mount Socket for all Full Extension Slides

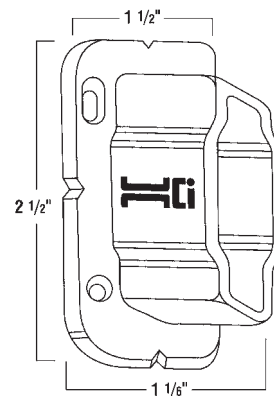
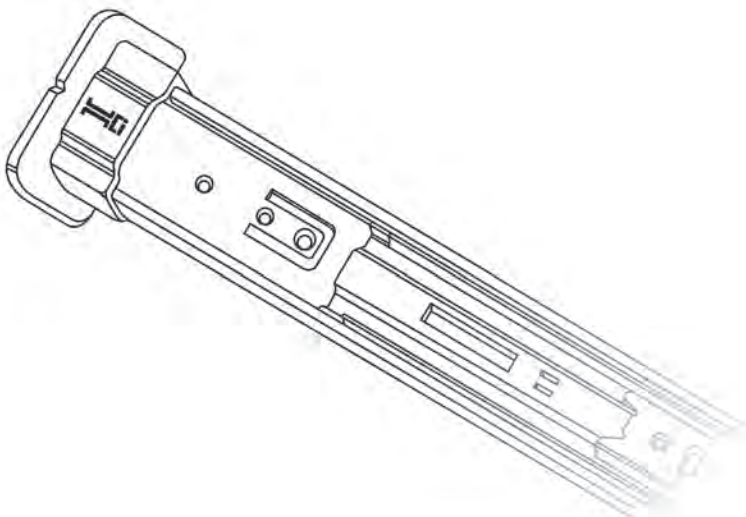

### ORDER NUMBERS

Left and Right ..... 25-132

Kitchens

Doors

Kitchen Accessories

Hinges

Drawer Slides

Plywood Melamine

Veneer Edgbanding

Laminate

Solid Surface

Closets

Furniture Hardware

Pulls & Knobs

Lighting

Grommets

Locks, Lock Systems

Molding, Carvings

Tools

Adhesives Solvents Abrasives

Chemicals Staples Screws

# SLIDES

## 250 Lb. Full Extension Drawer Slide

Kitchens

### Description

- LOAD rating 250 lbs.

Doors

Kitchen Accessories

### ORDER NUMBERS

12" .....	<b>25-432</b>	22" .....	<b>25-442</b>
14" .....	<b>25-434</b>	24" .....	<b>25-444</b>
16" .....	<b>25-436</b>	26" .....	<b>25-446</b>
18" .....	<b>25-438</b>	28" .....	<b>25-448</b>
20" .....	<b>25-440</b>		

Hinges

Drawer Slides

Plywood Melamine

Veneer Edgebanding

Laminate

Solid Surface

Closets

Furniture Hardware

Pulls & Knobs

Lighting

Grommets

Locks, Lock Systems

Molding, Carvings

Tools

Adhesives Solvents Abrasives

Chemicals Staples Screws

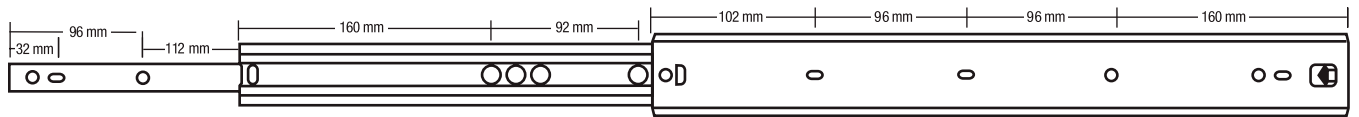
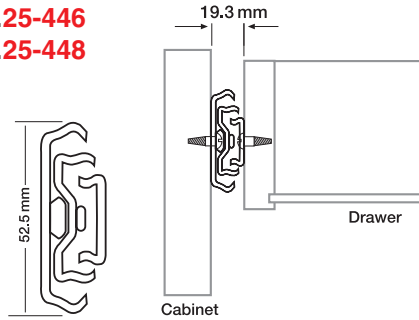

## Stainless Steel Slides

### Description

- Stainless Steel ball bearings
- Ideal for marine and outdoor applications or conditions where moisture is a factor

### ORDER NUMBERS

12" .....	<b>25-372</b>
14" .....	<b>25-374</b>
16" .....	<b>25-376</b>
18" .....	<b>25-378</b>
20" .....	<b>25-380</b>
22" .....	<b>25-382</b>
24" .....	<b>25-384</b>

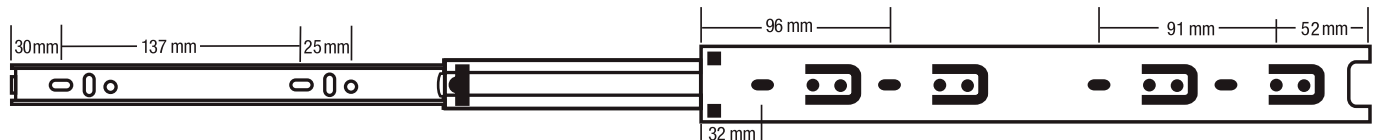
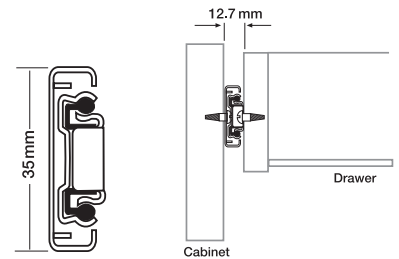
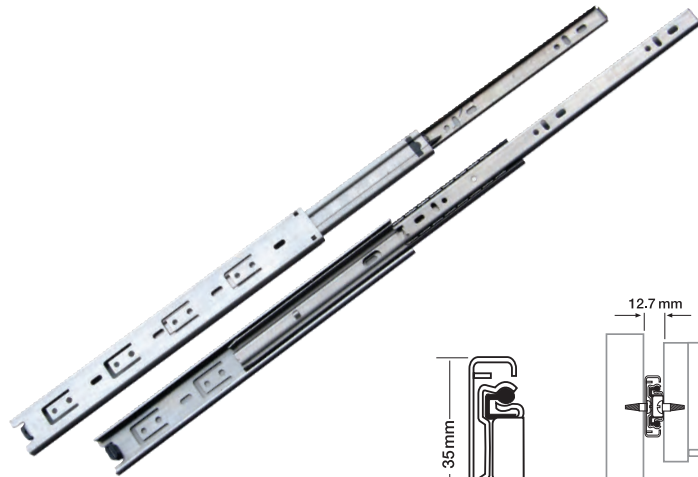

## Tilt Fitting



**Drawer runner with tilt fitting:** Special fitting mounts to drawer front or Pull-out. Suitable for cutting boards and Pull-out shelves in kitchen cabinets as well as Pull-out shelves in entertainment units and keyboard shelves.

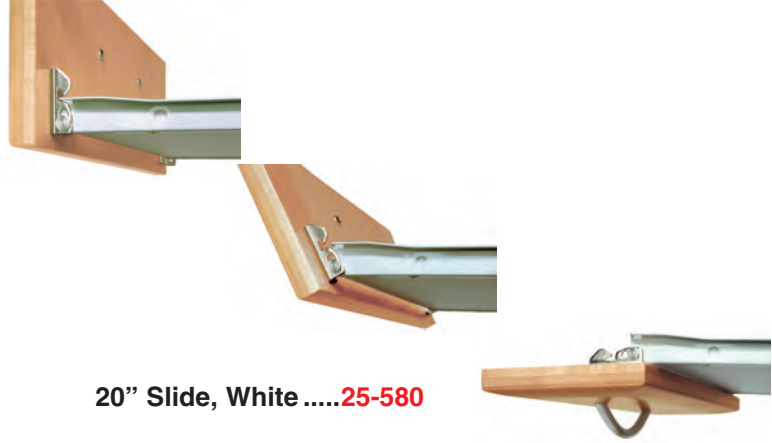
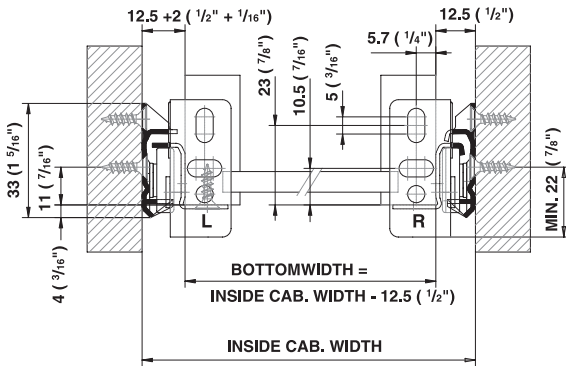

20" Slide, White .....25-580

### ORDER NUMBERS

- 14" ..... 25-574
- 16" ..... 25-576
- 18" ..... 25-578

## Mounting Slide

UNDER SURFACE SLIDE



- **Height Adjustment:** Positive hold-out and hold-in lock
- **Features:** Front edge beveled for user protection
- **LOAD rate:** 60 lbs. per pair based on 16" slides in normal usage
- **Mounting:** Top Mounting with holes for #8 pan head screws.

## Econo Keyboard Tray

with mouse-pad extension



ORDER NUMBER.....43-460



Kitchens

Doors

Kitchen Accessories

Hinges

Drawer Slides

Plywood Melamine

Veneer Edgebanding

Laminate

Solid Surface

Closets

Furniture Hardware

Pulls & Knobs

Lighting

Grommets

Locks, Lock Systems

Molding, Carvings

Tools

Adhesives Solvents Abrasives

Chemicals Staples Screws

## Ergonomic Keyboard Support

Kitchens  
Doors  
Kitchen Accessories  
Hinges

### Description

- Gel Pad For Wrist Comfort
- Ergonomic Controls For Tilt And Height
- Mouse Pad Swivels For Easy Concealment
- System Slides Under
- Black Finish

with Ball Bearing Track

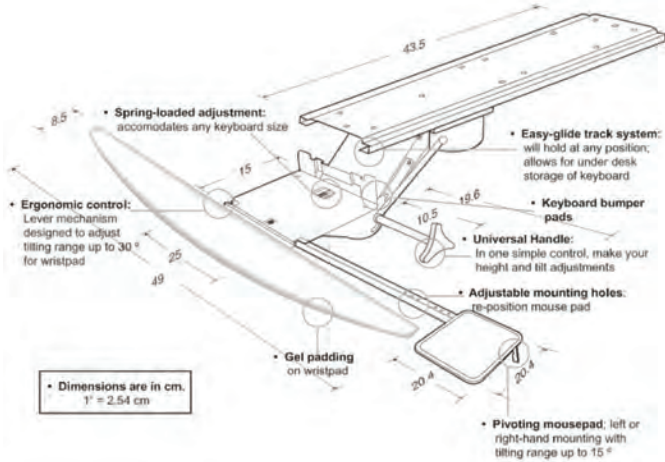

Order number .....43-406

Drawer Slides

Plywood Melamine

Veneer Edgebanding

Laminate

Solid Surface

Closets

Furniture Hardware

Pulls & Knobs

Lighting

Grommets

Locks, Lock Systems

Molding, Carvings

Tools

Adhesives Solvents Abrasives

Chemicals Staples Screws

## Adjustable Mounting Keyboard Slides

- **Height Adjustment:** Mounting brackets adjust 2-3/8" to 3-5/8"
- **Features:** Friction locking, front edge beveled for user protection
- **LOAD rate:** 60 lbs. per pair based on 16" slides in normal usage
- **Mounting:** Top Mounting with holes for #8 pan head screws.

### ORDER NUMBERS

- 14" .....25-584
- 16" .....25-586
- 18" .....25-588

Available in black only

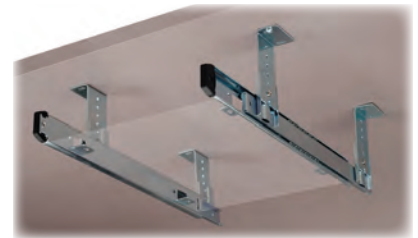

## CPU Holders



### Features

- Unit mounts underneath desk top
- CPU is secured by heavy duty adjustable straps that accommodate varying widths and heights
- Unit extends and rotates 360°
- Material: Steel with nylon straps

Order number .....43-408



### Features

- Stationary unit mounts underneath desk top
- Height and width can be easily adjusted
- Material: Steel

Order number .....43-410

## SELF CLOSING

- Aesthetic Looking Steel Structure
- Self-Closing Feature
- 2 Drawer Side Heights
- 7 Drawer Lengths – 86mm
- Electrostatic Paint
- 75 Lb. LOADING Capacity
- Safety Pull-Out Stop System
- 2 Dimensional Front Adjustment (Horizontal / Vertical)

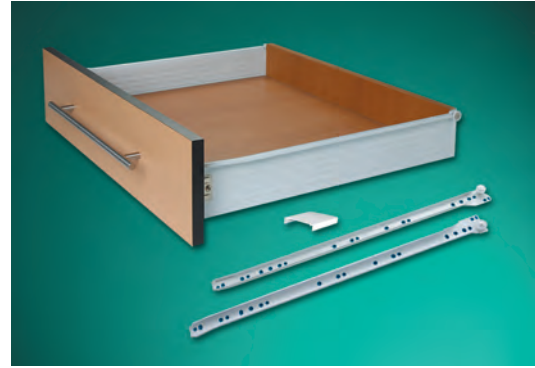

Kitchens

Doors

Kitchen Accessories

Hinges

Drawer Slides

### STANDARD DRAWER SAMBOX 150

HIT #	FINISH	MATERIAL	●/▼	PACKING	LENGTH IN CLOSED POSITION	LOSS OF EXTENSION	CAPACITY DYNAMIC LOAD	kg/box
H3.9150350	WHITE	STEEL	●	BULK	350mm. 14"	87mm.	75 lb.	7.24
			▼	5 SETS / BOX				
H3.9150400	WHITE	STEEL	●	BULK	400mm. 16"	97mm.	75 lb.	8.24
			▼	5 SETS / BOX				
H3.9150450	WHITE	STEEL	●	BULK	450mm. 18"	97mm.	75 lb.	9.36
			▼	5 SETS / BOX				
H3.9150500	WHITE	STEEL	●	BULK	500mm. 20"	97mm.	75 lb.	10.24
			▼	5 SETS / BOX				
H3.9150550	WHITE	STEEL	●	BULK	550mm. 22"	97mm.	75 lb.	11.02
			▼	5 SETS / BOX				

Plywood Melamine

Veneer Edgebanding

Laminate

Solid Surface

Closets

### STANDARD DRAWER SAMBOX 86

HIT #	FINISH	MATERIAL	●/▼	PACKING	LENGTH IN CLOSED POSITION	LOSS OF EXTENSION	CAPACITY DYNAMIC LOAD	kg/box
H3.9086250	WHITE	STEEL	●	BULK	250mm. 10"	87mm.	75 lb.	6.24
			▼	10 SETS / BOX				
H3.9086300	WHITE	STEEL	●	BULK	300mm. 12"	87mm.	75 lb.	7.24
			▼	10 SETS / BOX				
H3.9086350	WHITE	STEEL	●	BULK	350mm. 14"	97mm.	75 lb.	8.24
			▼	10 SETS / BOX				
H3.9086400	WHITE	STEEL	●	BULK	400mm. 16"	97mm.	75 lb.	9.36
			▼	10 SETS / BOX				
H3.9086450	WHITE	STEEL	●	BULK	450mm. 18"	97mm.	75 lb.	10.24
			▼	10 SETS / BOX				
H3.9086500	WHITE	STEEL	●	BULK	500mm. 20"	117mm.	75 lb.	11.11
			▼	10 SETS / BOX				
H3.9086550	WHITE	STEEL	●	BULK	550mm. 22"	117mm.	75 lb.	11.47
			▼	10 SETS / BOX				

Furniture Hardware

Pulls & Knobs

Lighting

Grommets

Locks, Lock Systems

Molding, Carvings



#### DECORATIVE PLASTIC COVERS FOR STANDARD DRAWERS



#### 86 & 150

		H3.9000001
		08 H3.9000008

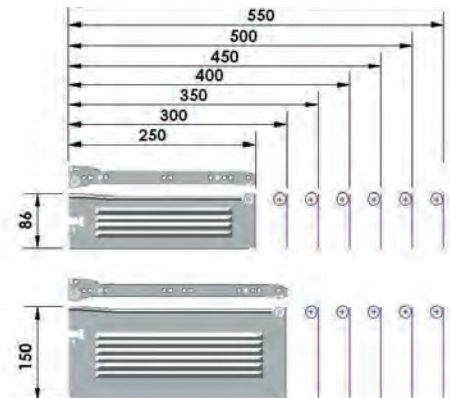

Tools

Adhesives Solvents Abrasives

Chemicals Staples Screws



## STANDARD DRAWER SAMBOX 86

Kitchens

Doors

Kitchen Accessories

Hinges

Drawer Slides

Plywood Melamine

Veneer Edgebanding

Laminate

Solid Surface

Closets

Furniture Hardware

Pulls & Knobs

Lighting

Grommets

Locks, Lock Systems

Molding, Carvings

Tools

Adhesives Solvents Abrasives

Chemicals Staples Screws

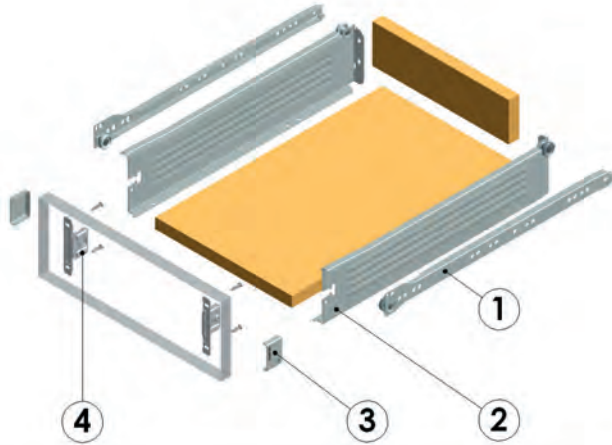

1. U type carcass profiles left+right
2. Drawer sides left+right
3. Plastic cover cap
4. Plastic front fixing brackets

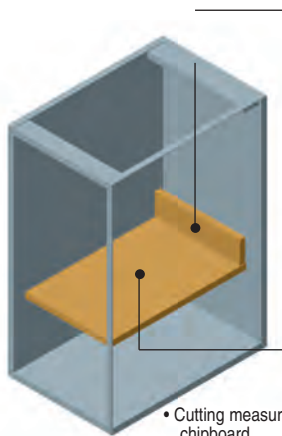
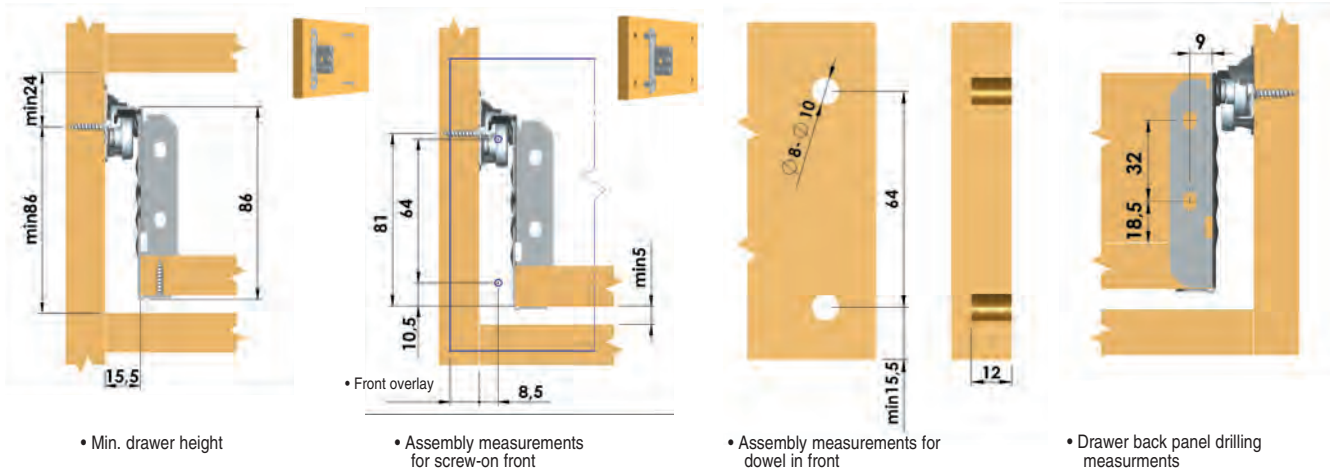
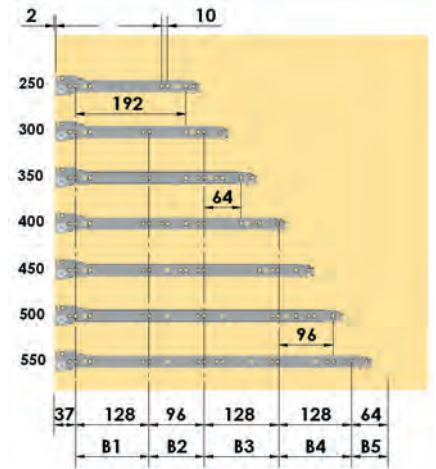

- WIDTH: WITH OF THE INTERNAL CARCASE: (min. 31mm. /max. 33mm.)
- HEIGHT: 71 mm. (for 16mm chipboard)  
79 mm. (for 8mm chipboard)

- WIDTH: WITH OF THE INTERNAL CARCASE: (min. 31mm. /max. 33mm.)
- LENGTH: SLIDE LENGTH IN mm. -1mm.

• Cutting measurements for chipboard

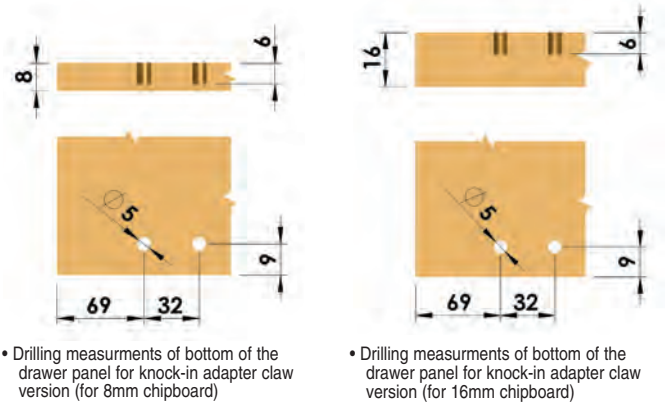

## STANDARD DRAWER SAMBOX 150

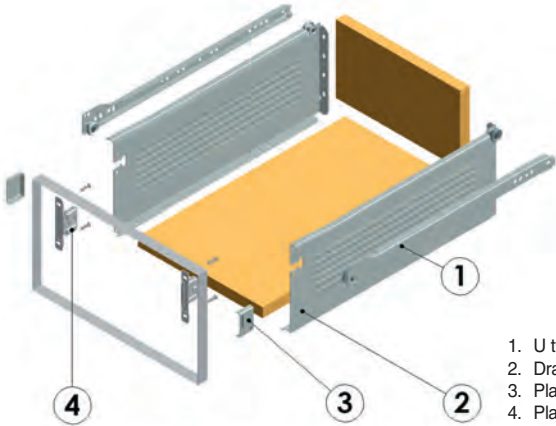

1. U type carcass profiles left+right
2. Drawer sides left+right
3. Plastic cover cap
4. Plastic front fixing brackets

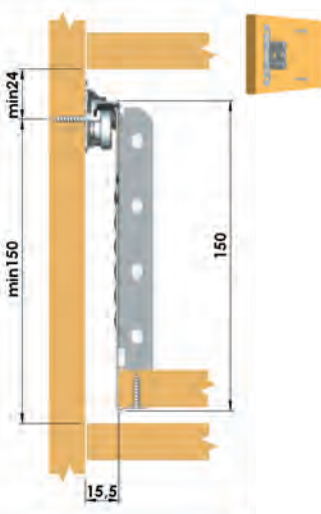
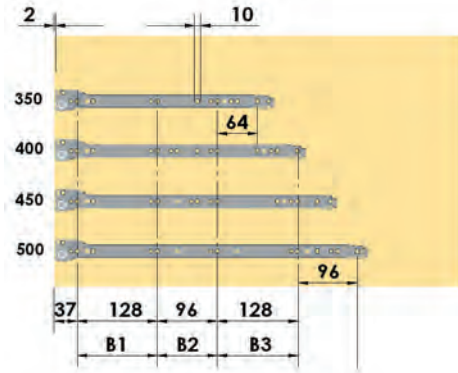

• Min. drawer height

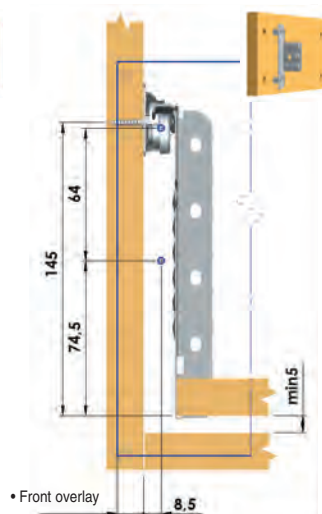

• Front overlay  
• Assembly measurements for screw-on front

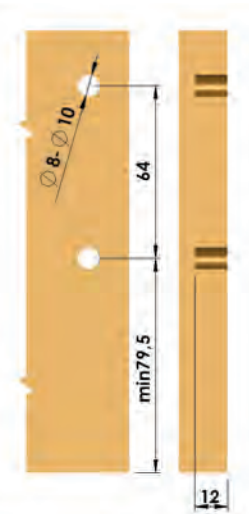

• Assembly measurements for dowel in front

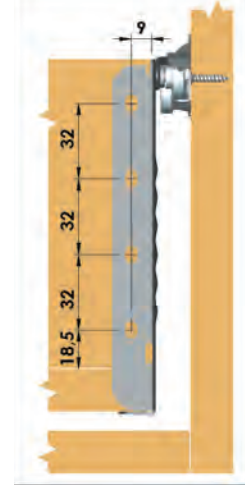

• Drawer back panel drilling measurements



• Drilling measurements of bottom of the drawer panel for knock-in adapter claw version (for 8mm chipboard)



• Drilling measurements of bottom of the drawer panel for knock-in adapter claw version (for 16mm chipboard)

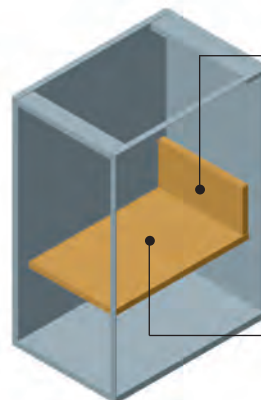

• Cutting measurements for chipboard

- WIDTH: WITH OF THE INTERNAL CARCASE: (min. 31mm. /max. 33mm.)
- HEIGHT: 135 mm. (for 16mm chipboard) 143 mm. (for 8mm chipboard)

- WIDTH: WITH OF THE INTERNAL CARCASE: (min. 31mm. /max. 33mm.)
- LENGTH: SLIDE LENGTH IN mm. -1mm.

Kitchens

Doors

Kitchen Accessories

Hinges

Drawer Slides

Plywood Melamine

Veneer Edgbanding

Laminate

Solid Surface

Closets

Furniture Hardware

Pulls & Knobs

Lighting

Grommets

Locks, Lock Systems

Molding, Carvings

Tools

Adhesives Solvents Abrasives

Chemicals Staples Screws

# SLIDES

Kitchens

Doors

Kitchen  
Accessories

Hinges

Drawer  
Slides



Plywood  
Melamine

Veneer  
Edgebanding

Laminate

Solid  
Surface

Closets



Furniture  
Hardware

Pulls  
&  
Knobs

Lighting

Grommets

Locks,  
Lock  
Systems

Molding,  
Carvings

Tools

Adhesives  
Solvents  
Abrasives

Chemicals  
Staples  
Screws



## U.S. Futaba, Inc.

## Flat Panel Wall Mount Single Arm

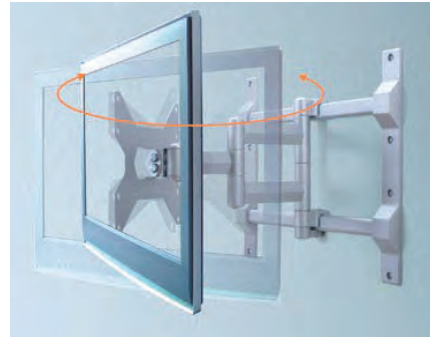
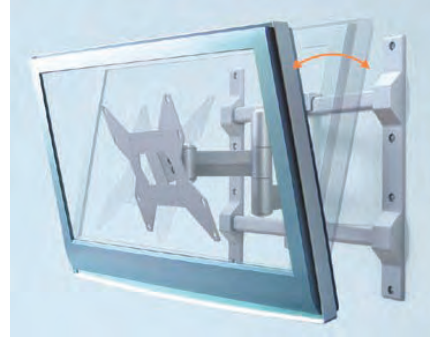
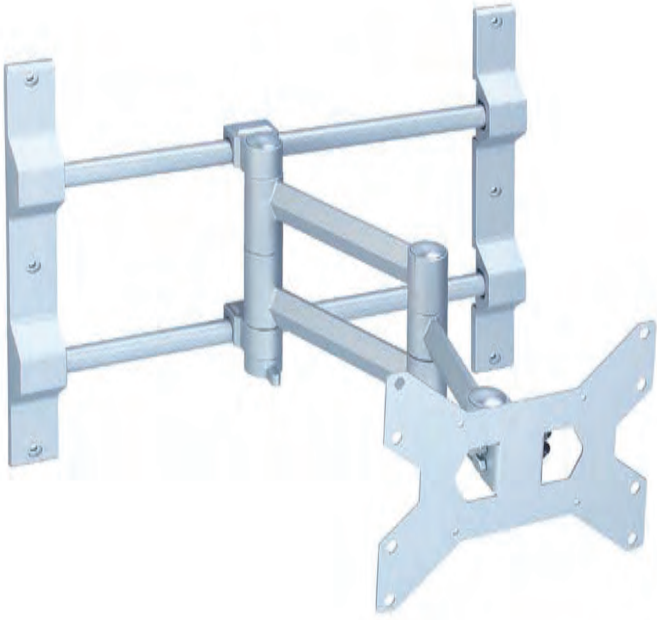

### Features

- ▶▶ Durable aluminum construction
- ▶▶ Includes both 100 mm and 200 mm VESA brackets
- ▶▶ Horizontal adjustment from 8" - 27"
- ▶▶ Vertical adjustment from 4-7/8" - 17"
- ▶▶ Extends, tilts and swivels
- ▶▶ Collapses to less than 3" depth
- ▶▶ Supports TVs from 20" - 32" up to 110 lbs

### Dimensions

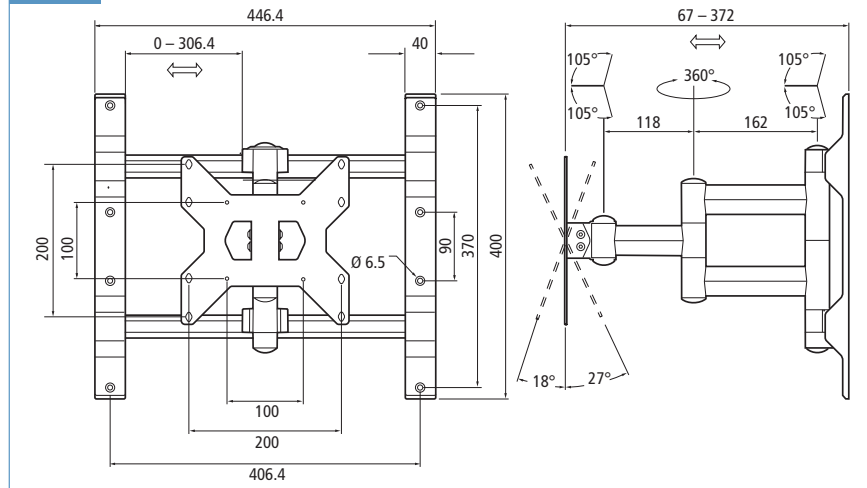

Kitchens

Doors

Kitchen  
Accessories

Hinges

Drawer  
Slides

Plywood  
Melamine

Veneer  
Edgebanding

Laminate

Solid  
Surface

Closets

Furniture  
Hardware

Pulls  
&  
Knobs

Lighting

Grommets

Locks,  
Lock  
Systems

Molding,  
Carvings

Tools

Adhesives  
Solvents  
Abrasives

Chemicals  
Staples  
Screws

## Flat Panel TV Lift - WHISPER 1000

Kitchens

Doors

Kitchen Accessories

Hinges

Drawer Slides

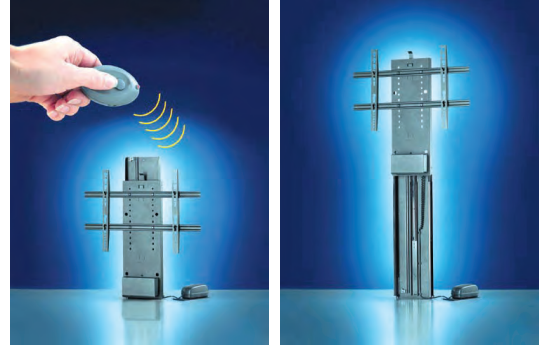

Plywood Melamine

Accommodates TVs 50" - 65"

Veneer Edgebanding

### Features

- ▶▶ Rack and pinion design with unique stability system
- ▶▶ Quiet operation
- ▶▶ Reverse safety function
- ▶▶ Requires only 2-13/16" depth behind the TV
- ▶▶ Requires a build in height of only 29-1/2"
- ▶▶ Weight capacity 225 lbs
- ▶▶ 39-3/8" of travel
- ▶▶ Simple and fast mounting
- ▶▶ IR remote available
- ▶▶ UL listed power supply

Laminate

Solid Surface

Closets

Furniture Hardware

Pulls & Knobs

Lighting

### Complete inside one carton

- ▶▶ Remote control (RF)
- ▶▶ Manual push switch
- ▶▶ Adjustable lid lifter
- ▶▶ Plug and play assembly
- ▶▶ Universal TV mounting bracket

Grommets

Locks, Lock Systems

Molding, Carvings

Tools

Adhesives Solvents Abrasives

Chemicals Staples Screws

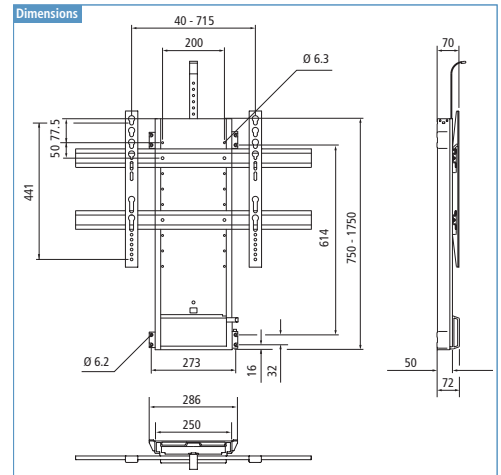
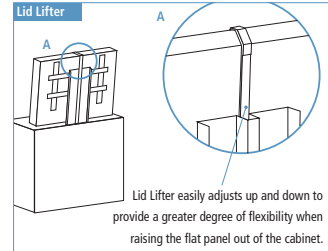
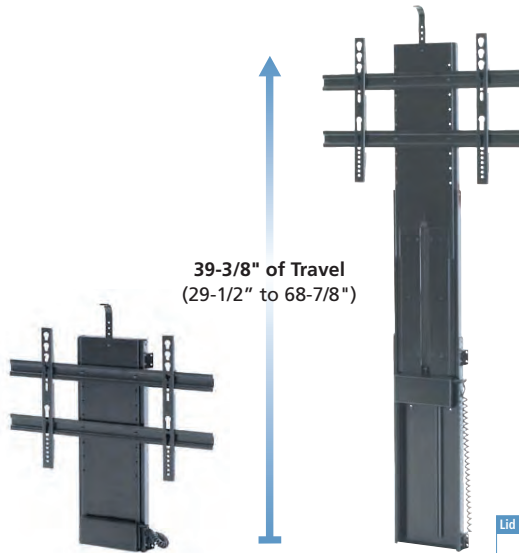

## Flat Panel TV Lift - WHISPER RIDE

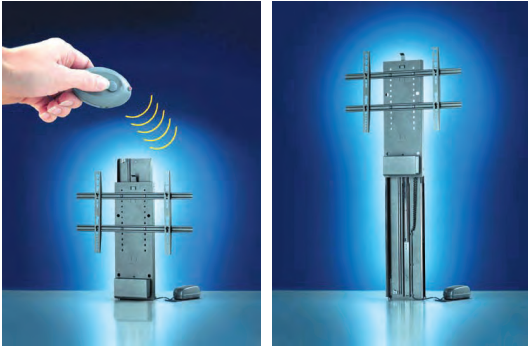

### Complete inside one carton

- ▶▶ Remote control (RF)
- ▶▶ Manual push switch
- ▶▶ Adjustable lid lifter
- ▶▶ Plug and play assembly
- ▶▶ Universal TV mounting bracket

### Accommodates TVs 37" – 48"

#### Features

- ▶▶ Rack and pinion design with unique stability system
- ▶▶ Uses German Bosch® motor for reliable and quiet operation
- ▶▶ Requires only 2-3/4" depth behind the TV
- ▶▶ Weight capacity 200 lbs
- ▶▶ 29-1/2" of travel
- ▶▶ Simple and fast mounting
- ▶▶ UL listed power supply

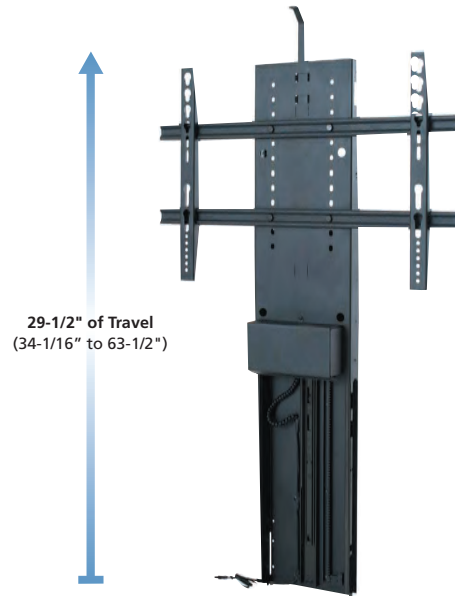
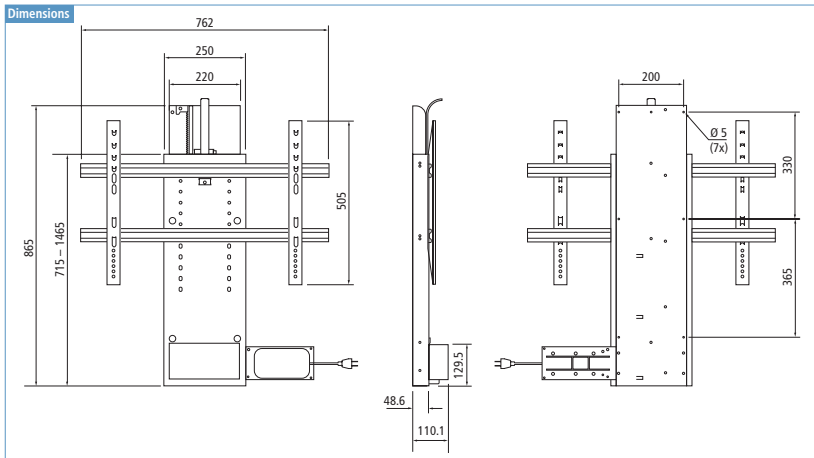
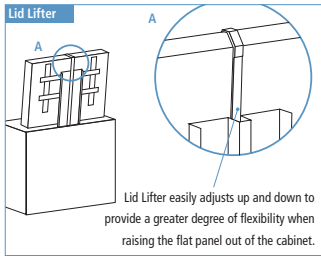

Kitchens

Doors

Kitchen Accessories

Hinges

Drawer Slides

Plywood Melamine

Veneer Edgebanding

Laminate

Solid Surface

Closets



Furniture Hardware

Pulls & Knobs

Lighting

Grommets

Locks, Lock Systems

Molding, Carvings

Tools

Adhesives Solvents Abrasives

Chemicals Staples Screws

## Flat Panel TV Lift - WHISPER 700

Kitchens

Doors

Kitchen  
Accessories

Hinges

Drawer  
Slides

Plywood  
Melamine

Veneer  
Edgebanding

Laminate

Solid  
Surface

Closets

Furniture  
Hardware

Pulls  
&  
Knobs

Lighting

Grommets

Locks,  
Lock  
Systems

Molding,  
Carvings

Tools

Adhesives  
Solvents  
Abrasives

Chemicals  
Staples  
Screws



Accommodates TVs 26"– 42"

### Features

- ▶▶ Rack and pinion design with unique stability system
- ▶▶ Quiet operation
- ▶▶ Reverse safety function
- ▶▶ Requires only 2-13/16" depth behind the TV
- ▶▶ Weight capacity 220 lbs
- ▶▶ 27-3/16" of travel
- ▶▶ Simple and fast mounting
- ▶▶ UL listed power supply

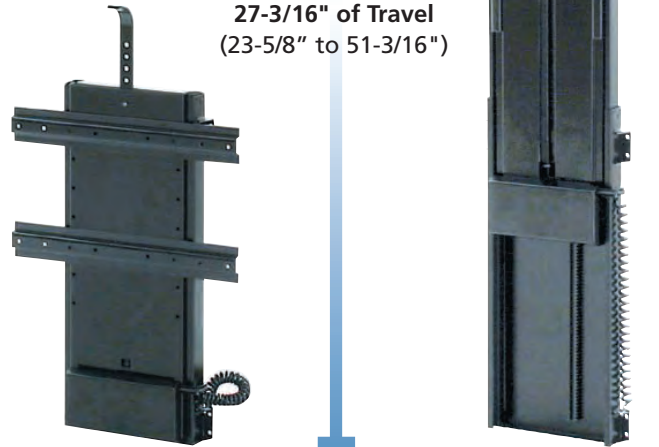

## Flat Panel TV Lift - WHISPER 700

### Complete inside one carton

- ▶▶ Remote control (RF)
- ▶▶ Manual push switch
- ▶▶ Adjustable lid lifter
- ▶▶ Plug and play assembly
- ▶▶ Universal TV mounting bracket

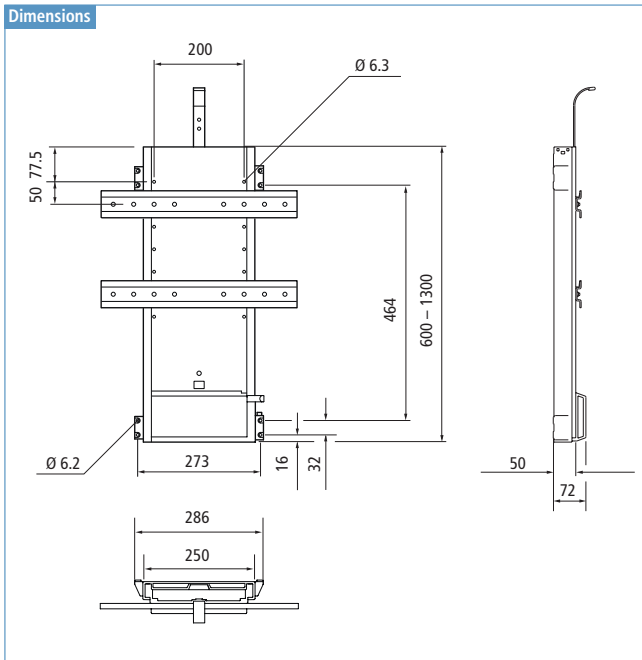
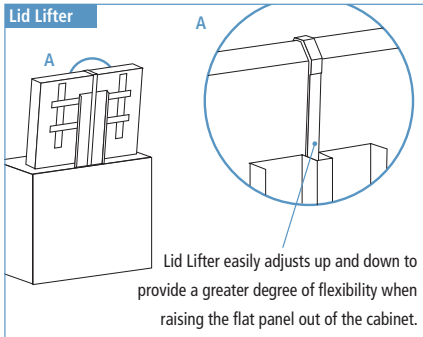

Kitchens

Doors

Kitchen  
Accessories

Hinges

Drawer  
Slides

Plywood  
Melamine

Veneer  
Edgebanding

Laminate

Solid  
Surface

Closets

Furniture  
Hardware

Pulls  
&  
Knobs

Lighting

Grommets

Locks,  
Lock  
Systems

Molding,  
Carvings

Tools

Adhesives  
Solvents  
Abrasives

Chemicals  
Staples  
Screws



## Flat Panel TV Lift - VERSALIFT

Kitchens

Doors

Kitchen  
Accessories

Hinges

Drawer  
Slides



Plywood  
Melamine

Accommodates TVs 10"– 26"

Veneer  
Edgebanding

### Features

Laminate

▶ The remote control lift designed for multiple applications

Solid  
Surface

▶ Perfect for raising and lowering TVs, desk monitors and cabinet shelves

Closets

▶ Ideal for limited space applications in boats, RVs, footboards, end tables and flat mounted in base cabinets

Furniture  
Hardware

▶ Weight capacity 110 lbs

▶ 18" of travel

Pulls  
&  
Knobs

▶ Accommodates TVs/monitors up to 26"

▶ UL listed power supply



Lighting

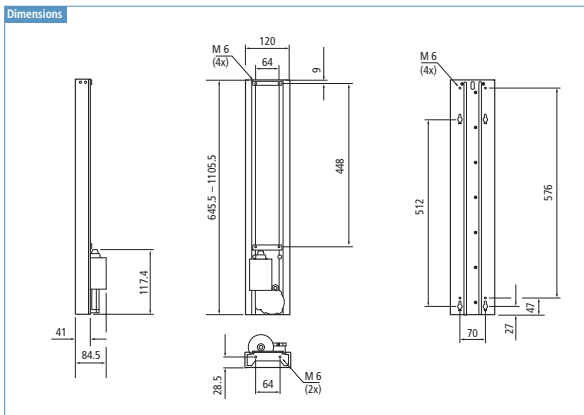

Grommets

Locks,  
Lock  
Systems

Molding,  
Carvings

Tools

Adhesives  
Solvents  
Abrasives

Chemicals  
Staples  
Screws

### Complete inside one carton:

- ▶ Remote control (RF)
- ▶ Manual push switch
- ▶ Plug and play assembly
- ▶ Universal TV mounting bracket

